

# KATO KC-30

## Hydraulic Compact Telescopic Crawler Crane

**Lifting Capacity  
2.9 TONNES**

- *Versatile lifting in confined areas. Only 1.75 mtr tail swing.*
- *Lifts and carries up to 1.75 tonnes.*
- *Hydraulic control for smooth, precise, and quiet operation.*
- *Fully equipped for man riding.*
- *Automatic Electronic A.S.L.I with safety overload cut out device.*
- *Rubber tracks – will travel on rough and soft terrain, and will not mark finished surfaces.*
- *Available for long or short term rental.*

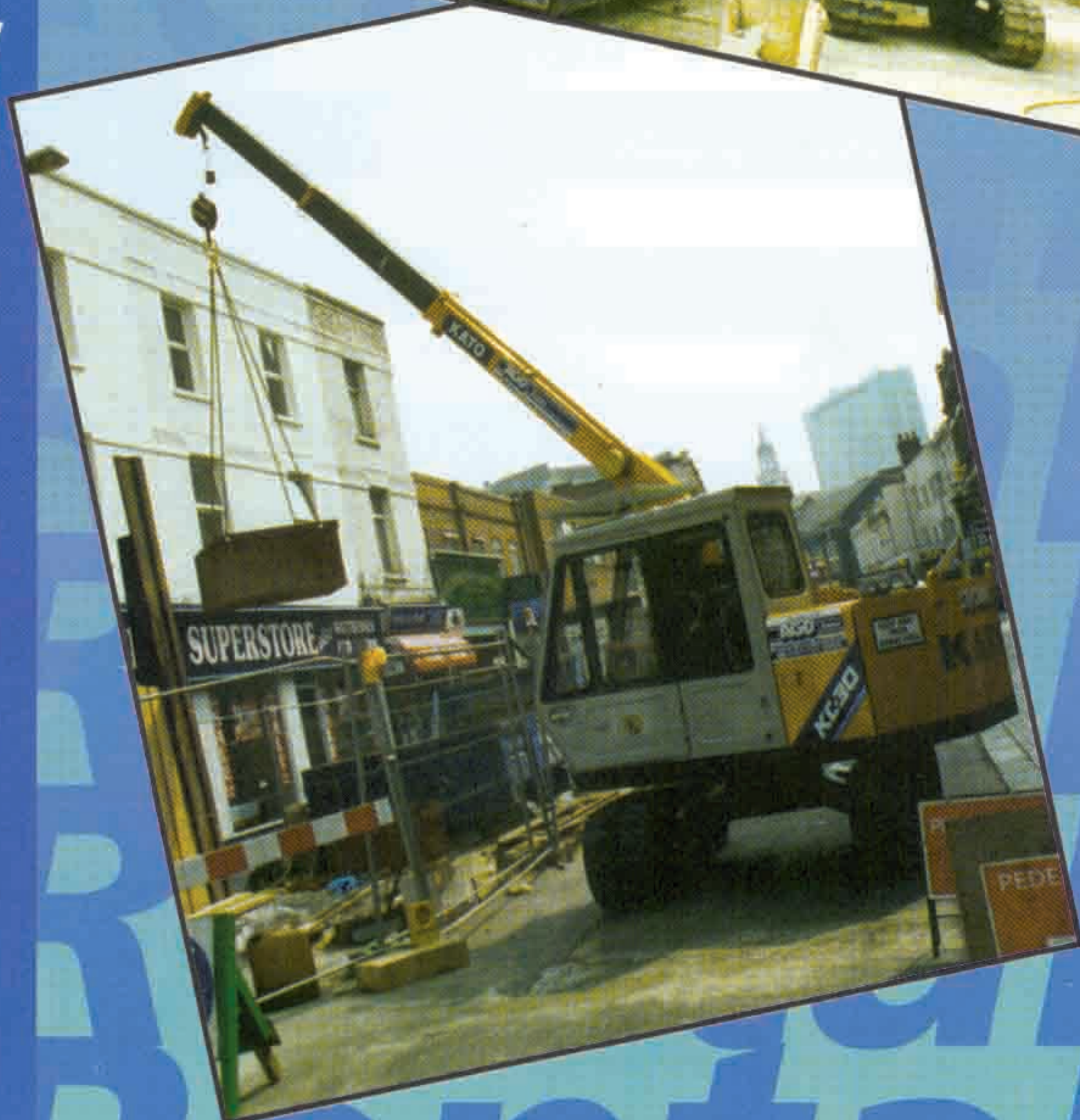

# AGD

## Rental

*The Crawler Crane  
Professionals*

# KATO KC-30

*The Crawler Crane Professionals*

## Rated Lifting Loads (tonnes) 3.32 - 7.72 mtr boom

Radius mtr	Main Boom 3.32 - 5.545 mtr		Main Boom 7.72 mtr
	Status 360 deg	Mobile 360 deg	Static
2.3	2.93	1.75	
2.6			2.43
3.0	1.98	1.18	1.98
3.5	1.58	0.94	1.58
4.0	1.33	0.79	1.33
4.5	1.08	0.64	1.08
5.0	0.93	0.55	0.93
5.5	0.78	0.46	0.78
5.77	0.73	0.43	
6.0			0.73
6.5			0.63
7.0			0.58
7.5			0.53
8.0			0.48

## Crane Performance

Crane Capacity	2.93 ton x 2.3 mtr rad
Operating Radius	1.09 - 8.0 mtr
Max Lift Above Ground	9.0 mtr
Hoist Speed	48 mtr/min (single line)
Boom Hoist Speed	12.0 sec (1-78 deg)
Boom Ext Speed	14.0 sec

## Wire Rope

Size	8 mm
Min Length	50 mtr

## Travel Gear

Tracks	Bonded Rubber
Traction Method	Track Mounted Hydraulic Motor

## Hydraulic System

Pumps	Variable Piston and Gear Pumps
Safety Devices	Automatic Hydraulic Locking Device and Hydraulic Safety Valves
Tank Capacity	110 ltrs

## Weight

Total Weight inc hook	5850 kgs
-----------------------	----------

## Performance

Min Slew Radius	1750 mm
Bearing Pressure	0.30 kgf/cm sq
Swing Angle	360 deg
Travel Speed	5,5/3,7 km/hour
Gradeability	58%

## Engine

Type	Mitubishi S4F Direct Injection
Rated Horsepower	55ps @ 2,000 rpm
Max Torque	18.5 Kgf-m @ 1650 rpm
Fuel Tank Capacity	140 ltrs

## Notes

The weight of the hook block (30kgs), and lifting tackle should be considered to be part of the load.

The rated loads are based upon crane structural strength and stability.

The duties refer to a crane working on firm and level ground.

Mobile duties apply only to boom lengths up to 5.545 mtrs maximum. Travel on firm and level ground only with the load as near to the floor as possible. Travel at low speed avoiding sudden stops and starts.

## Working Dimesions (unit:mm)

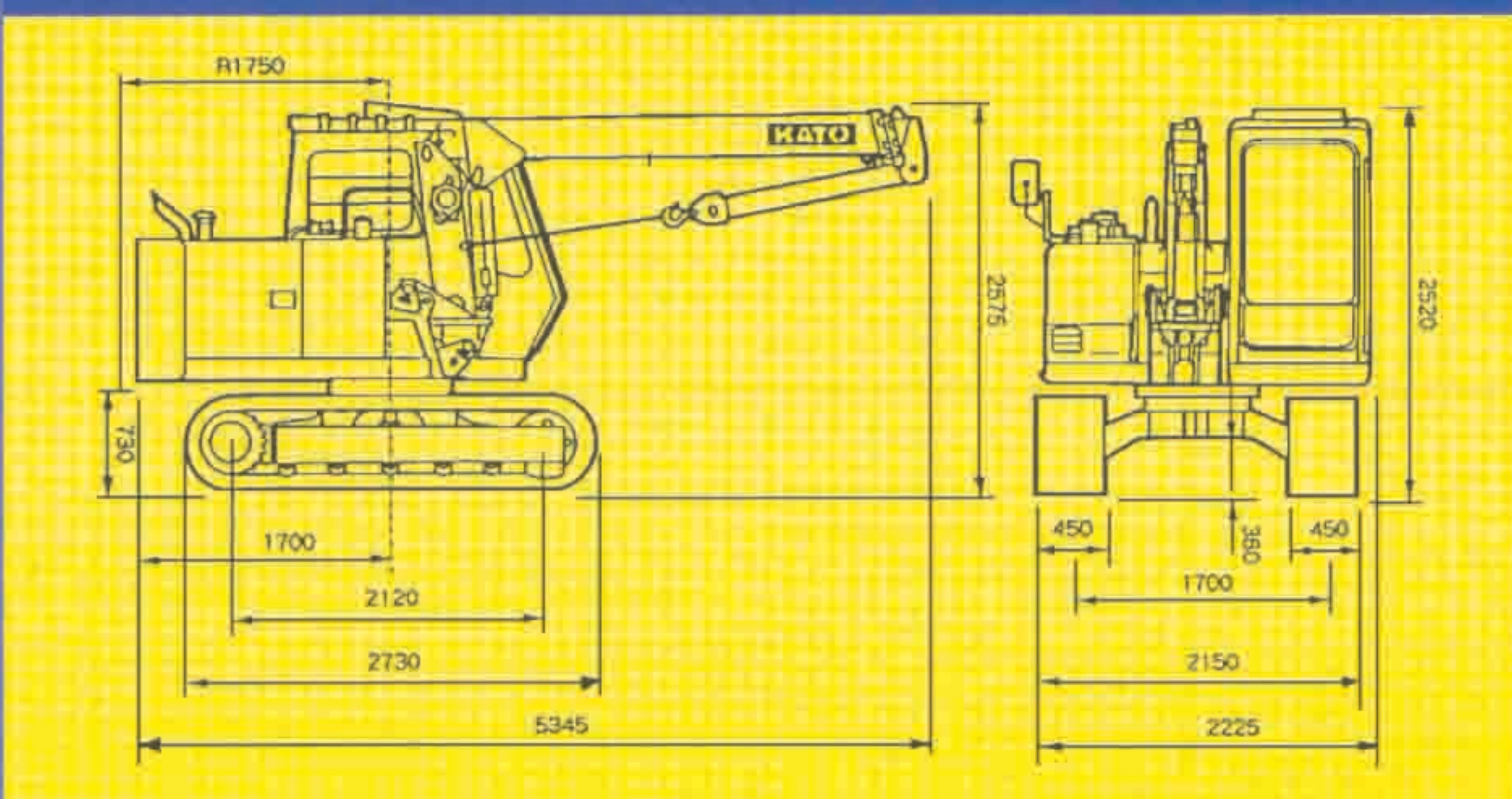

## Radius Diagram (unit:mtr)

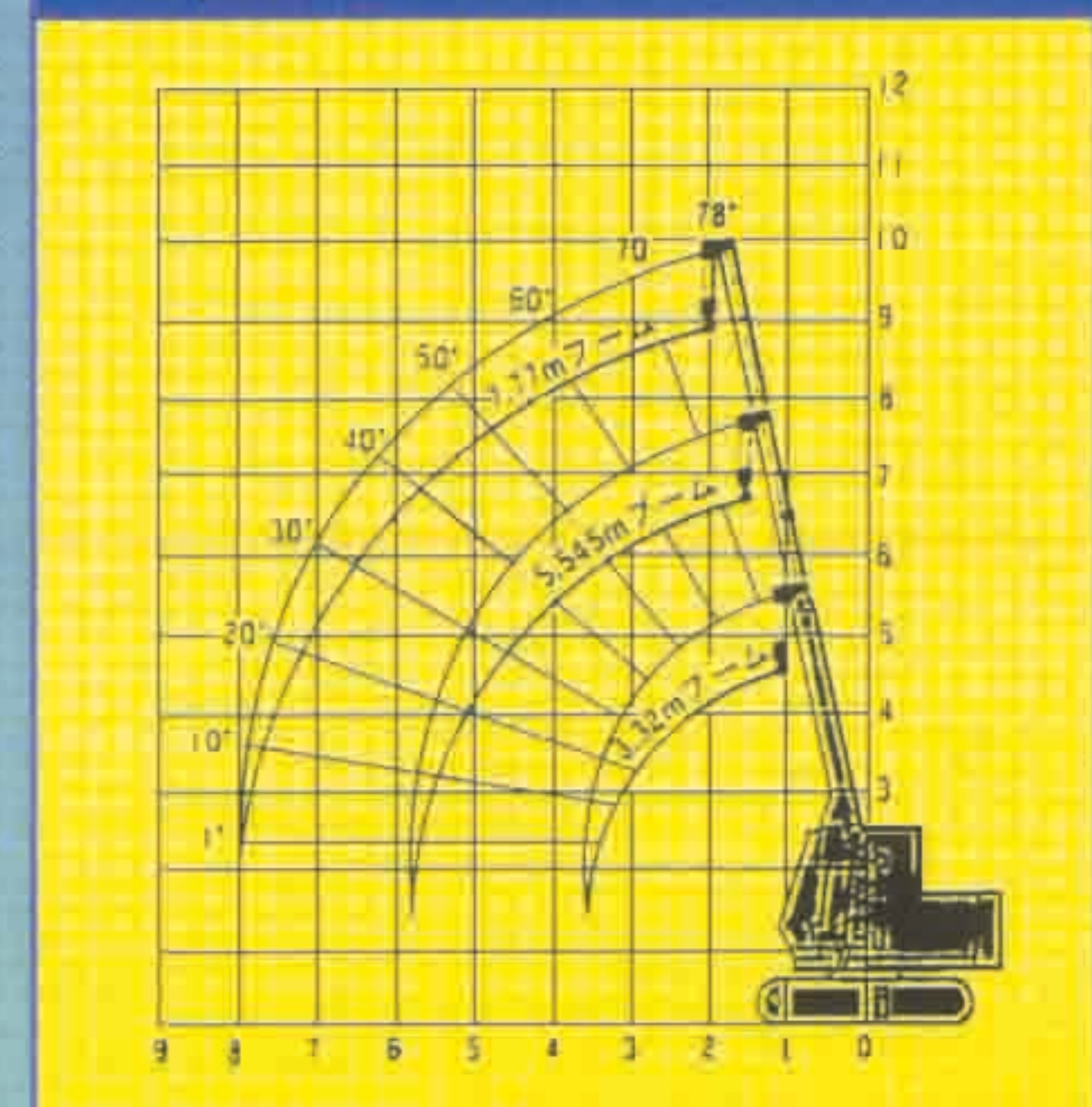

# AGD Rental