

# CCH500-3II

IHI

## Fully Hydraulic Crawler Spanner Crane

Lifting Capacity 50 metric tons

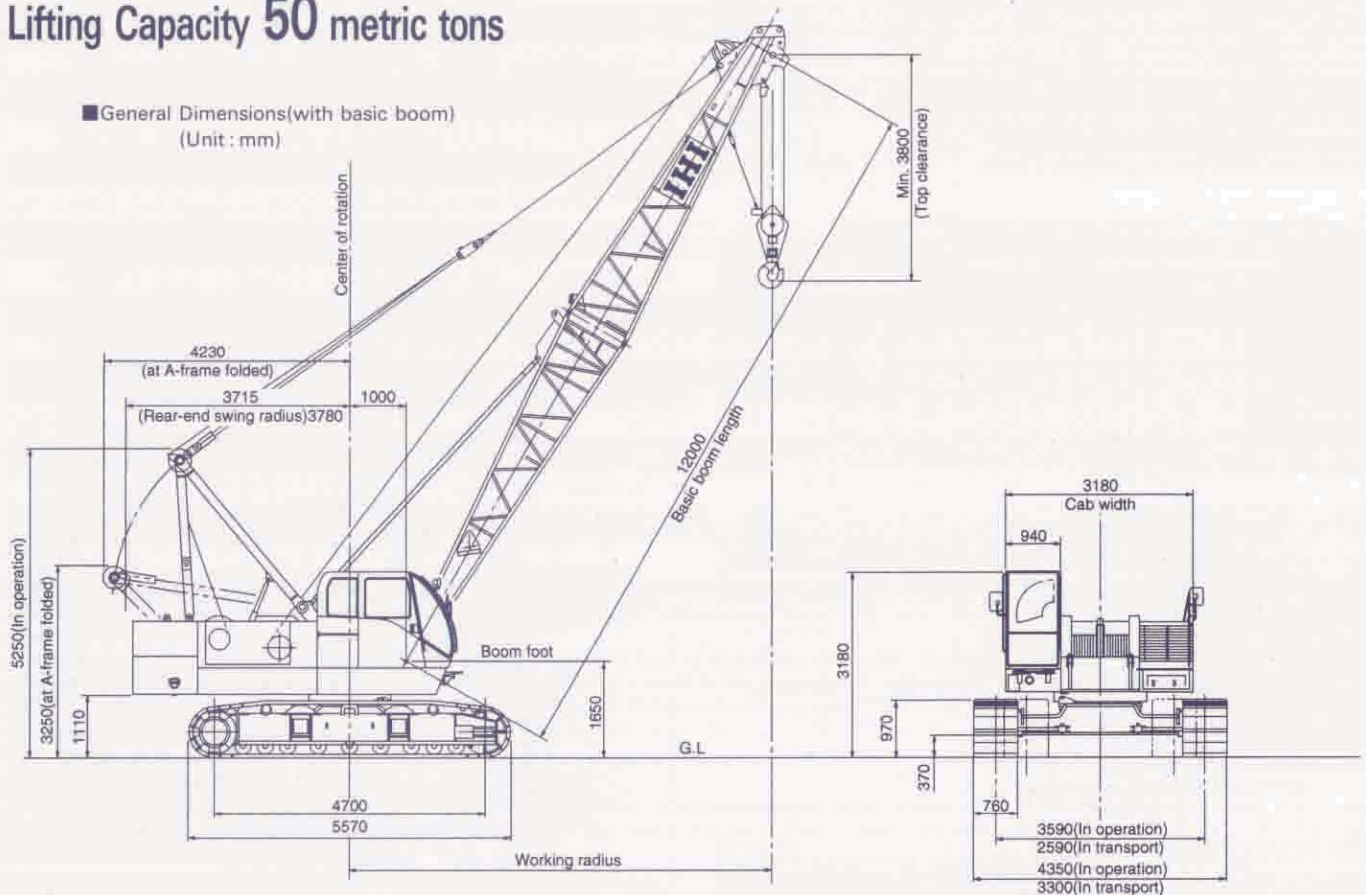

### ■ Specification

Performance	
Swing speed	3.5rpm
Travel speed	≈ 1.6km/h(1mph)
Gradeability	40%(Approx.22)
Engine	
Make	HINO MOTOR
Model	HO7CT(with turbo)diesel engine 4-cylinder, water cooled, overhead valve
Type	Direct injection diesel engine
Total piston displacement	6.728 l
Rated output	180PS/2,100rpm
Fuel tank capacity	225 l
Battery	12v × 120AH × 2pcs.
Load hoist system(Main&Aux.)	
Hydraulic motor	Variable displacement axial piston type
Reduction gear	One-stage planetary gear and single stage spur gear
Hoist drum	Dual drums on inline individual shaft, independent hydraulic motor driven, lagging type with lebus grooved drum
Clutch	Internal expanding band type
Brake	External contracting type
Drum lock	Ratchet lock
Boom hoist system	
Motor	Axial piston type
Reduction gear	Two stage planetary gear
Hoist drum	Lebus grooved drum
Brake	Automatic spring-loaded hydraulically released wet type/multi-disk
Drum lock	Ratchet lock

\* Travel speed changes depending on the load.

### ■ Standard equipment

- **Instrument**
    - Engine tachometer(Hour meter)
    - Hydraulic oil pressure gauge(for control circuit)
    - Fuel level gauge
    - Engine coolant thermo indicator
    - Engine oil pressure indicator
    - Hydraulic oil thermo indicator
  - **Lighting**
    - Work light 24v×80w×2
    - Room light 24v×20w×1
  - **Safety device**
    - Automatic stop for hook overwinding
    - Automatic stop for boom overwinding
    - Telescopic boom limit stop
    - Swing lock
    - Main and Aux. drum lock
    - Safety valve for hydraulic circuit
    - Counter balance valve
    - Control lever locking device
  - **Standard accessories**
    - Windshield wiper
    - Roof glass wiper
    - Sunvisor
    - Sun shade
    - Storage pouch
    - Reclining operator's seat
    - Floor mat
    - Steps for operator's cab (foldable type)
    - Radio
    - Cigarette lighter
    - Ash tray
- Rearview mirrors(R/L)  
Horn  
Swing warning flasher  
Travel warning flasher  
Low-noise cab  
Bronze tinted glass  
Electrical engine throttle control  
Hydraulic assist brake (Main & Aux. winch)  
Winch mode selector (Main & Aux. winch)  
Ultra low speed control  
Wire mesh boom walkway(for inner boom)  
Plug socket(24v)  
Fuel filling pump  
\* "A"frame(High gantry)erecting device

IHI Construction Machinery Limited

## Crane specifications

Max.lifting capacity(metric ton)×working radius(m)	50×3.7	
Max.boom length,main(main+jib boom)(m)	51(42+15)	
Rope speed	Main drum hoist/lowering(m/min)	*100/70·50/35
	Aux.drums hoist/lowering(m/min)	*100/70·50/35
	Boom drum hoist/lowering(m/min)	*60
Part line	Hook block capacity(ton)×part line	50×10
	Hook block capacity(ton)×part line	5.8×1
	Boom drum hoist/lowering part line	12
Counterweight(ton)	16	
Total operating weight(ton)	49.4	
Boom length(m)	12	
Hook block capacity(ton)	50	
Average ground bearing pressure(kg/cm <sup>2</sup> )	0.64	

\*The rope speed changes depending on the load.

## Combination of main boom and jib boom

Jib boom length(m)	Main boom length(m)													
	12	15	18	21	24	27	30	33	36	39	42	45	48	51
1	●	●	●	●	●	●	●	●	●	●	●	●	●	●
6	●	●	●	●	●	●	●	●	●	●	●	●	●	●
9	●	●	●	●	●	●	●	●	●	●	●	●	●	●
12	●	●	●	●	●	●	●	●	●	●	●	●	●	●
15	●	●	●	●	●	●	●	●	●	●	●	●	●	●

●:Applicable combination

## Wire rope

Place of use	Rope diameter(mm)/Guaranteed strength(ton)	Rope type
Main drum	20.0/30.0	A
Aux.drums	20.0/30.0	A
Boom hoist	16.0/21.8	B
Boom suspension	31.5/74.9	A
Jib boom suspension	26.0/49.9	A
Jib strut suspension	26.0/49.9	A

Rope type A:6XF(29)IWRC regular Z lay

B:6XWS(31)T IWRC regular Z lay

Length of wire rope to be decided according to the ordered boom length

## Boom composition

(Unit: m)

	Boom length	Boom composition
Standard	12	6.5(inner)+5.5(outer)
Option	15	6.5+3+5.5
Option	18	6.5+3+3+5.5
Option	21	6.5+3+6+5.5
Option	24	6.5+3+3+6+5.5
Option	27	6.5+3+6+6+5.5
Option	30	6.5+3+6+9+5.5
Option	33	6.5+3+3+6+9+5.5
Option	36	6.5+3+3+9+9+5.5
Option	39	6.5+3+6+9+9+5.5
Option	42	6.5+3+3+6+9+9+5.5
Option	45	6.5+3+3+9+9+9+5.5
Option	48	6.5+3+6+9+9+9+5.5
Option	51	6.5+3+3+6+9+9+9+5.5

\*:Required middle suspension for boom length 39m and longer

## Jib Boom composition

(Unit: m)

Jib Boom length	Jib Boom composition
1	3(inner)+3(outer)
9	3+3+3
12	3+3+3+3
15	3+3+6+3

## Working range(No loaded condition)

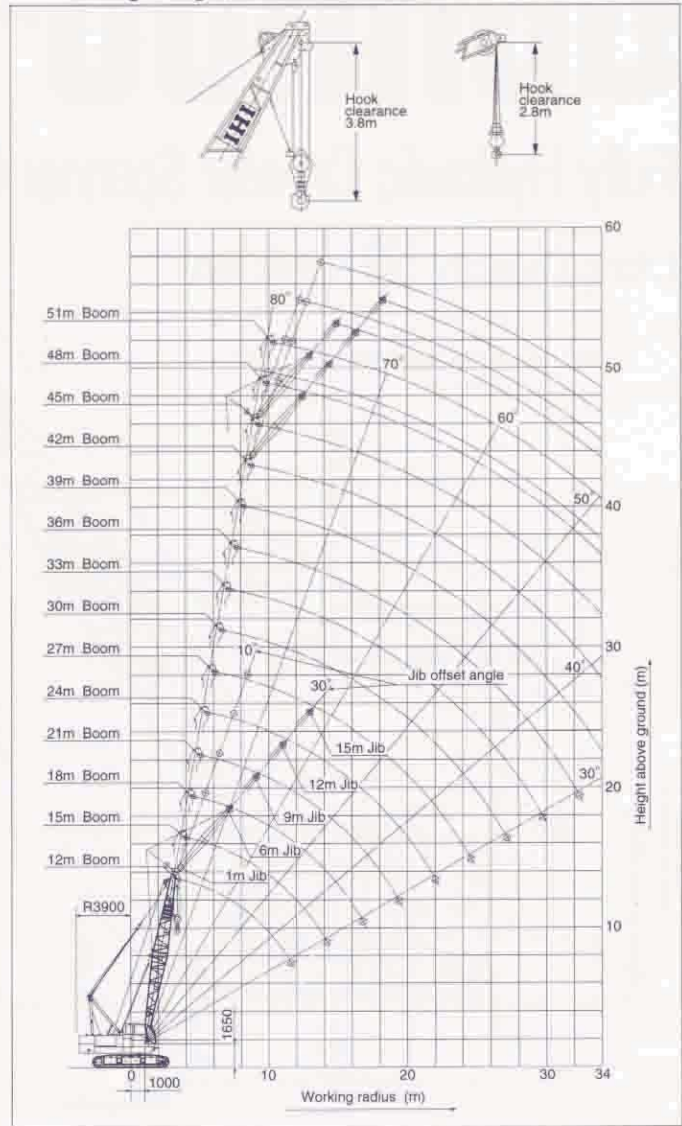

# Lifting magnet

CCH500-3II

## General layout

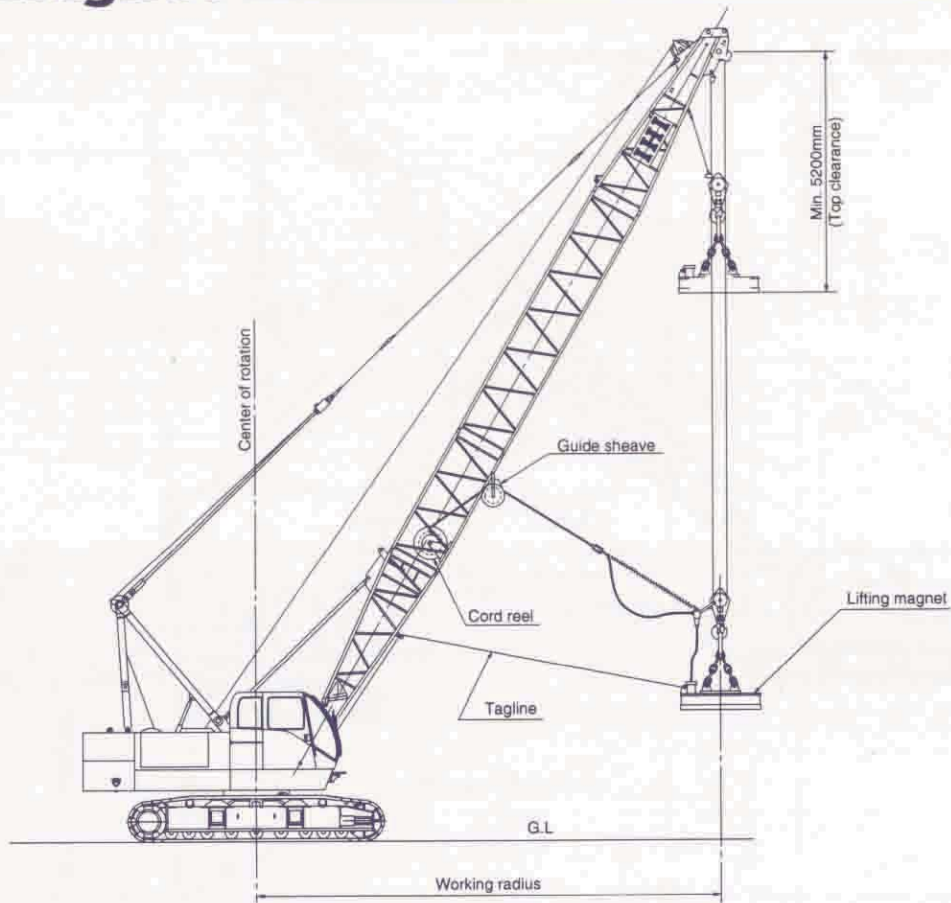

## Lifting magnet crane specifications

Max. lifting capacity (metric ton) × working radius (m)	25 × 3	
Boom length (m)	12 ~ 21	
Magnet diameter (mm)	1500	1800
Weight (ton)	2.7	4.2
Voltage	DC-220V	DC-220V
Generator capacity (kW/rpm)	20/1800	25/1800
Lifting capacity (ton)	Ingot	18
	Punched scrap	0.5~0.9
	Scrap	1.2~1.9
	Pig iron	1.3~1.9
Operating weight with 18m boom and 1500mm dia.magnet (ton)	52.2	53.7
Counterweight (ton)	16	16
Average ground bearing pressure (kg/cm <sup>2</sup> )	0.66	0.68

## Wire rope

Place of use	Rope diameter(mm)/Guaranteed strength(ton)	Rope type
Load hoist	20.0/30.0	A
Boom hoist	16.0/21.8	B
Boom suspension	31.5/74.9	A
Tagline	10.0/5.5	C

Rope type A : 6 × Fi (29) IWRC regular Z lay

B : 6 × WS (31) T IWRC regular Z lay

C : 6 × (19) fiber core regular Z lay

Length of wire rope to be decided according to the ordered boom length.

## Working range(with 18m boom & 1.0m<sup>3</sup>bucket) (Unit : mm)

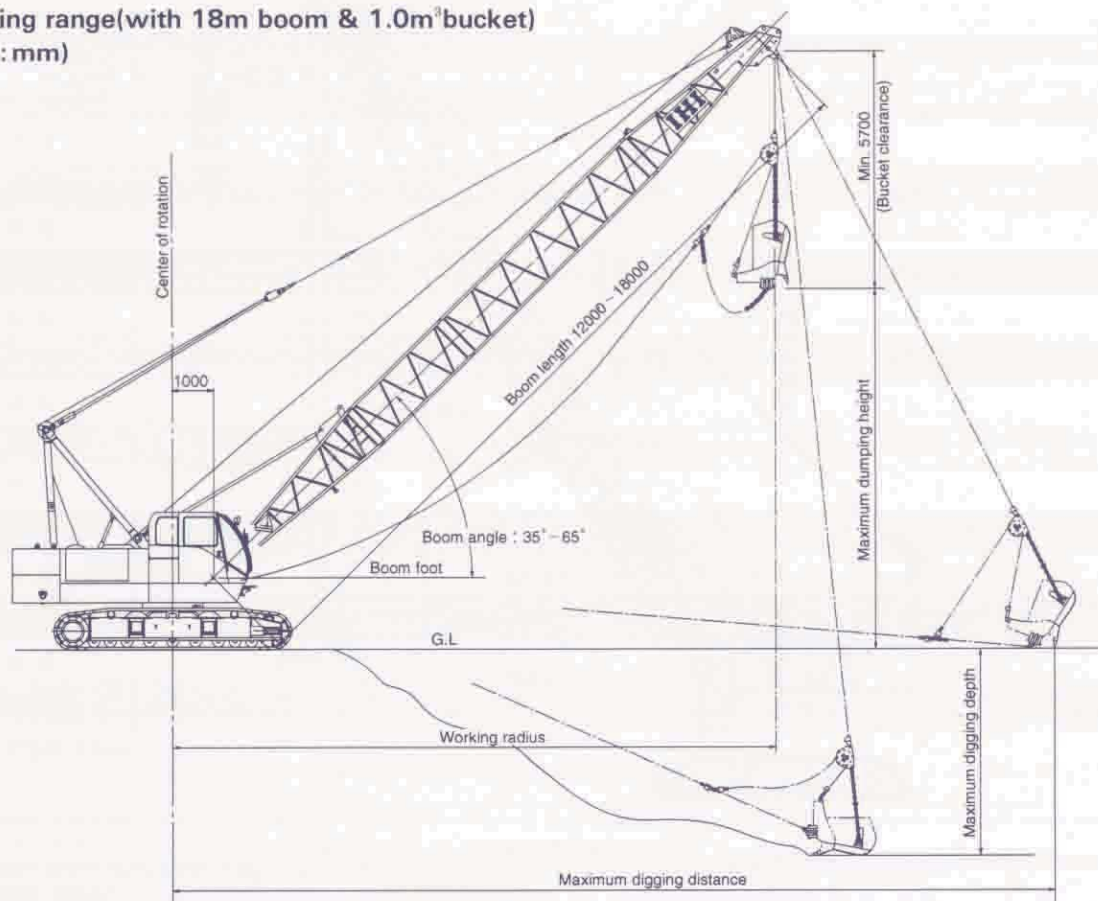

### Dragline specifications

Max.digging distance(m)	21.7(18m boom+1.0m <sup>3</sup> bucket)	
Max.dumping height(m)	10.9(18m boom+1.0m <sup>3</sup> bucket)	
Max.digging depth(m)	9.6(18m boom+1.0m <sup>3</sup> bucket)	
Rope speed	Bucket hoist(m/min)	*100/70·50/35
	Bucket digging(m/min)	*100/70·50/35
	Boom hoist and lowering (m/min)	*60
Part line	Bucket hoist	1
	Bucket digging	1
	Boom hoist	12
Counterweight(ton)	16.0	
Total operating weight(ton) (Boom length 18m) (Bucket capacity 1.0m <sup>3</sup> )	50.4	
Average ground bearing pressure(kg/cm <sup>2</sup> ) (Boom length 18m) (Bucket capacity 1.0m <sup>3</sup> )	0.63	

\* : The rope speed changes depending on the load.

### Dragline bucket specifications

Classification	Type	Capacity(m <sup>3</sup> )	Weight(ton)
Option	GP	0.6	0.93
Option	GP	0.8	1.17
Standard	GP	1.0	1.40
Option	LD	1.2	1.60

GP : General purpose digging  
LD : Light digging, scraping

### Wire rope

Place of use	Rope diameter(mm)/Guaranteed strength(ton)	Rope type
Hoist rope	20.0/30.0	A
Drag rope	20.0/30.0	C
Boom hoist	16.0/21.8	B
Boom suspension	31.5/74.9	A
Dump rope	16.0/19.2	A

Rope type A : 6×F(29)IWRC regular Z lay  
B : 6×WS(31)T IWRC regular Z lay  
C : T7×7+F(29)Toughsuper

Length of wire rope to be decided according to the ordered boom length.  
One (1) Sheave type boom point is recommended to dragline work.

### Working range and rated loads

Boom length(m)	12.0			15.0			18.0		
	30°	40°	50°	30°	40°	50°	30°	40°	50°
Working radius(m)	11.7	10.5	9.1	14.3	12.8	11.0	16.9	15.1	12.9
Rated lifting load(metric ton)	4.5	4.5	4.5	4.5	4.5	4.5	4.5	4.5	4.5
Max.digging distance(m)	15.1	14.8	14.1	18.4	18.0	17.1	21.7	21.2	20.1
Max.digging depth(m)	8.6	8.3	7.7	10.8	10.8	10.1	10.8	10.8	10.8
Max.dumping height(m)	1.7	3.5	5.0	3.2	5.4	7.3	4.7	7.3	9.6

#### Notes

- Rated loads is the total of the bucket's deadweight and grabbed load's weight. The total weight of this must not exceed the value in the table above.
- Above capacities are based on 1.0m<sup>3</sup> standard bucket.
- The reach of bucket and digging depth differ according to the bucket size and type, in addition to the operational conditions.
- Above working range is based on standard wire rope length as follows.  
Drag rope.....28m  
Hoist rope.....40m
- Selection of the bucket type must be made according to the soil conditions. In particular do not use 1.2m<sup>3</sup> bucket for solid soil or clay soil.

## Working range(with 18m boom & 1.0m<sup>3</sup>bucket) (Unit : mm)

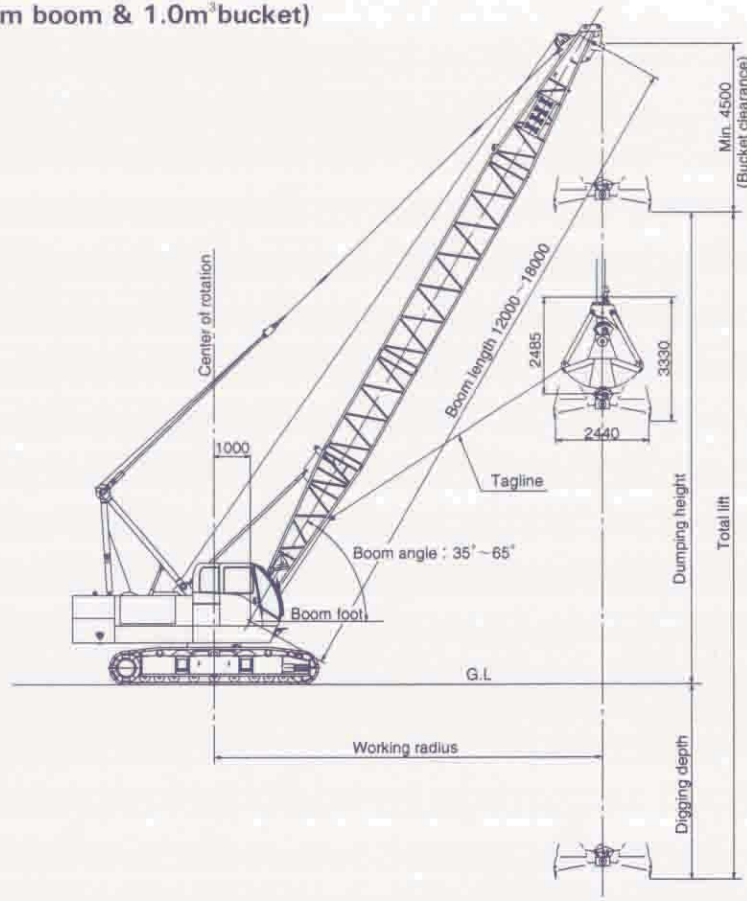

### Clamshell specifications

Max.lift above ground(m)		13.3(18m boom+1.0m <sup>3</sup> bucket)	
Rope speed	Bucket closing	(m/min)	*100/70·50/35
	Bucket holding	(m/min)	*100/70·50/35
	Boom hoist and lowering	(m/min)	*60
part line	Bucket closing	6(for all types bucket)	
	Bucket holding	1(for all types bucket)	
	Boom hoist	12	
Rated lifting load(Bucket+load) (ton)		5	
Counterweight (ton)		16	
Total operating weight (ton) (Boom length 18m) (Bucket capacity 1.0m <sup>3</sup> )		51.3	
Average ground bearing pressure(kg/cm <sup>2</sup> ) (Boom length 18m) (Bucket capacity 1.0m <sup>3</sup> )		0.65	

\*: The rope speed changes depending on the load.

### Clamshell bucket specifications

Classification	Type	Capacity(m <sup>3</sup> )	Weight(ton)
Option	HD	0.6	3.0
Option	GP	0.8	2.22
Standard	GP	1.0	2.5
Option	WR	1.0	2.0
Option	WR	1.25	1.6

Bucket type(purpose)  
 HD : Heavyduty (civil engineering, construction)  
 GP : General purpose (heavy load handling)  
 WR : Wide rehandling(medium load rehandling)

### Wire rope

Place of use	Rope diameter(mm)/Guaranteed strength(ton)	Rope type
Bucket closing	20.0/30.0	A
Bucket holding	20.0/30.0	A
Boom hoist	16.0/21.8	B
Boom suspension	31.5/74.9	A
Tagline	10.0/5.5	C

Rope type A : 6×Fi(29)IWRC regular Z lay  
 B : 6×WS(31)T IWRC regular Z lay  
 C : 6×(19)fiber core regular Z lay  
 Length of wire rope to be decided according to the ordered boom length.

### Working range and rated loads

Boom length (m)	12.0				15.0				18.0			
	35°	45°	55°	65°	35°	45°	55°	65°	35°	45°	55°	65°
Working radius (m)	11.1	9.8	8.3	6.5	13.6	12.0	10.0	7.7	16.1	14.1	11.7	9.0
Rated lifting load (metric ton)	5.0	5.0	5.0	5.0	5.0	5.0	5.0	5.0	5.0	5.0	5.0	5.0
Total lift (m)	23.0	23.0	23.0	23.0	20.0	20.0	20.0	20.0	17.0	17.0	17.0	17.0
Max.dumping height	3.8	5.4	6.8	7.9	5.5	7.5	9.2	10.6	7.2	9.6	11.7	13.3
Max.digging depth	19.2	17.6	16.2	15.1	14.5	12.5	10.8	9.4	9.8	7.4	5.3	3.7

- Notes
- Rated loads are the upper limit of the "bucket weight+load" during clamshell work. Use a bucket suitable for the kind of the load required so that the rated load figures in the table are not exceeded.
  - The maximum digging height is for a standard 1.0m<sup>3</sup>bucket.
  - The maximum digging depth is for standard wire rope length as follows.  
 Closing..... 65m  
 Holding..... 53m  
 Tagline..... 50m

## Jib rated lifting loads

(Unit:metric ton)

Boom length(m)	30.0										33.0							
	Jib length(m)		6.0		9.0		12.0		15.0		6.0		9.0		12.0		15.0	
	Offset angle	1.0	6.0	9.0	12.0	15.0	1.0	6.0	9.0	12.0	15.0	1.0	6.0	9.0	12.0	15.0		
Working radius(m)	~	10'	30'	10'	30'	10'	30'	10'	30'	~	10'	30'	10'	30'	10'	30'		
7.0	5.80									7.6mx 5.80								
8.0	5.80	8.6mx 5.00								5.80								
9.0	5.80	5.00			9.7mx 5.00					5.80	9.1mx 5.00							
10.0	5.80	5.00	10.4mx 5.00	5.00				10.5mx 4.00		11.0mx 2.60		5.80	5.00	10.9mx 5.00	10.2mx 5.00		11.0mx 4.00	
12.0	5.80	5.00	5.00	5.00	12.3mx 4.10	4.00			2.60		5.80	5.00	5.00	5.00	12.9mx 4.10	4.00	11.5mx 2.60	
14.0	5.80	5.00	5.00	5.00	4.10	4.00	3.20	2.60		15.5mx 2.30	5.80	5.00	5.00	5.00	4.10	4.00	14.6mx 3.20	
16.0	5.80	5.00	5.00	5.00	4.10	4.00	3.20	2.60	2.30	5.80	5.00	5.00	5.00	4.10	4.00	3.20	2.60	2.30
18.0	5.10	5.00	5.00	5.00	4.10	4.00	3.20	2.60	2.30	5.00	5.00	5.00	5.00	4.10	4.00	3.20	2.60	2.30
20.0	4.40	4.70	4.70	4.70	4.10	4.00	3.20	2.60	2.30	4.30	4.60	4.60	4.60	4.10	4.00	3.20	2.60	2.30
22.0	3.80	4.10	4.10	4.10	4.10	4.00	3.20	2.60	2.30	3.70	4.00	4.00	4.00	4.00	4.00	3.20	2.60	2.30
24.0	3.30	3.60	3.60	3.60	3.60	3.60	3.20	2.60	2.30	3.20	3.50	3.50	3.50	3.50	3.50	3.20	2.60	2.30
26.0	2.80	3.10	3.10	3.10	3.10	3.10	3.10	2.60	2.30	2.70	3.00	3.00	3.00	3.00	3.00	3.00	2.60	2.30
28.0	2.50	2.80	2.80	2.80	2.80	2.80	2.80	2.60	2.30	2.40	2.70	2.70	2.70	2.70	2.70	2.70	2.60	2.30
30.0		2.45	2.45	2.45	2.45	2.45	2.45	2.45	2.30	2.05	2.35	2.35	2.35	2.35	2.35	2.35	2.35	2.30
32.0		2.15	2.15	2.15	2.15	2.15	2.15	2.15	2.15	30.8mx 1.90	2.05	2.05	2.05	2.05	2.05	2.05	2.05	2.05
34.0		33.2mx 1.90	33.6mx 1.85	1.80	1.80	1.80	1.80	1.80	1.80		1.75	1.75	1.75	1.75	1.75	1.75	1.75	1.75

Boom length(m)	36.0										39.0								
	Jib length(m)		6.0		9.0		12.0		15.0		6.0		9.0		12.0		15.0		
	Offset angle	1.0	6.0	9.0	12.0	15.0	1.0	6.0	9.0	12.0	15.0	1.0	6.0	9.0	12.0	15.0			
Working radius(m)	~	10'	30'	10'	30'	10'	30'	10'	30'	~	10'	30'	10'	30'	10'	30'			
8.0	8.1mx 5.80									8.6mx 5.80									
9.0	5.80	9.7mx 5.00								5.80									
10.0	5.80	5.00	11.4mx 5.00	10.8mx 5.00				11.6mx 4.00		5.80	10.2mx 5.00			11.3mx 5.00					
12.0	5.80	5.00	5.00	5.00	13.4mx 4.10	4.00			12.1mx 2.60	5.80	5.00	5.00	5.00		12.1mx 4.00		12.6mx 2.60		
14.0	5.80	5.00	5.00	5.00	4.10	4.00		15.1mx 3.20	2.60	5.80	5.00	5.00	5.00	4.10	4.00	15.6mx 3.20	2.60		
16.0	5.80	5.00	5.00	5.00	4.10	4.00	3.20	2.60		16.5mx 2.30	5.70	5.00	5.00	5.00	4.10	4.00	3.20	2.60	17.1mx 2.30
18.0	4.90	5.00	5.00	5.00	4.10	4.00	3.20	2.60	2.30	4.80	5.00	5.00	5.00	4.10	4.00	3.20	2.60	2.30	
20.0	4.20	4.50	4.50	4.50	4.10	4.00	3.20	2.60	2.30	4.10	4.40	4.40	4.40	4.10	4.00	3.20	2.60	2.30	
22.0	3.60	3.90	3.90	3.90	3.90	3.90	3.20	2.60	2.30	3.50	3.80	3.80	3.80	3.80	3.80	3.20	2.60	2.30	
24.0	3.10	3.40	3.40	3.40	3.40	3.40	3.20	2.60	2.30	3.00	3.30	3.30	3.30	3.30	3.30	3.20	2.60	2.30	
26.0	2.65	2.95	2.95	2.95	2.95	2.95	2.95	2.60	2.30	2.55	2.85	2.85	2.85	2.85	2.85	2.85	2.60	2.30	
28.0	2.30	2.60	2.60	2.60	2.60	2.60	2.60	2.60	2.30	2.20	2.50	2.50	2.50	2.50	2.50	2.50	2.50	2.30	
30.0	2.00	2.30	2.30	2.30	2.30	2.30	2.30	2.30	2.30	1.90	2.20	2.20	2.20	2.20	2.20	2.20	2.20	2.20	
32.0	1.70	2.00	2.00	2.00	2.00	2.00	2.00	2.00	2.00	1.60	1.90	1.90	1.90	1.90	1.90	1.90	1.90	1.90	
34.0	33.2mx 1.90	1.70	1.70	1.70	1.70	1.70	1.70	1.70	1.70	1.30	1.60	1.60	1.60	1.60	1.60	1.60	1.60	1.60	

Boom length(m)	42.0										45.0						48.0
	Jib length(m)		6.0		9.0		12.0		15.0		6.0		9.0		1.0		
	Offset angle	1.0	6.0	9.0	12.0	15.0	1.0	6.0	9.0	1.0	6.0	9.0	1.0				
Working radius(m)	~	10'	30'	10'	30'	10'	30'	10'	30'	~	10'	30'	10'	30'	~		
9.0	8.1mx 5.80									9.7mx 5.80							
10.0	5.80	10.7mx 5.00			11.8mx 6.00					5.80	11.2mx 5.00				10.2mx 5.80		
12.0	5.80	5.00	12.5mx 5.00	5.00		12.6mx 4.00			13.1mx 2.60	5.80	5.00	13.0mx 5.00	12.4mx 5.00		5.80		
14.0	5.80	5.00	5.00	5.00	14.4mx 4.10	4.00			2.60	5.80	5.00	5.00	5.00	15.0mx 4.10	5.80		
16.0	5.60	5.00	5.00	5.00	4.10	4.00		16.1mx 3.20	2.60	17.6mx 2.30	5.50	5.00	5.00	5.00	4.10	5.40	
18.0	4.70	5.00	5.00	5.00	4.10	4.00	3.20	2.60	2.30	4.60	4.90	4.90	4.90	4.10	4.50		
20.0	4.00	4.30	4.30	4.30	4.10	4.00	3.20	2.60	2.30	3.90	4.20	4.20	4.20	4.10	3.80		
22.0	3.40	3.70	3.70	3.70	3.70	3.70	3.20	2.60	2.30	3.30	3.60	3.60	3.60	3.60	3.20		
24.0	2.90	3.10	3.10	3.10	3.10	3.10	3.20	2.60	2.30	2.80	3.10	3.10	3.10	3.10	2.70		
26.0	2.45	2.75	2.75	2.75	2.75	2.75	2.75	2.60	2.30	2.35	2.65	2.65	2.65	2.65	2.25		
28.0	2.10	2.40	2.40	2.40	2.40	2.40	2.40	2.40	2.30	2.00	2.30	2.30	2.30	2.30	1.90		
30.0	1.80	2.10	2.10	2.10	2.10	2.10	2.10	2.10	2.10	1.70	2.00	2.00	2.00	2.00	1.60		
32.0	1.50	1.80	1.80	1.80	1.80	1.80	1.80	1.80	1.80	1.40	1.70	1.70	1.70	1.70	1.30		
34.0	1.50	1.50	1.50	1.50	1.50	1.50	1.50	1.50	1.50	1.10	1.40	1.40	1.40	1.40	1.05		

### Notes

- Above rated loads are based on firm level ground, within 78% of tipping load at any point 360 throughout with front stability of 1.15 or more.
- Working radius is horizontal distance from center of rotation to a vertical line through the center of gravity of the load.
- When main hook block installed actual loads that can be lifted with the jib hook should reduced following weights from the above chart.  
50ton hook block.....0.49ton  
25ton hook block.....0.35ton  
15ton hook block.....0.31ton  
5.8ton hook block.....0.12ton
- One part line jib hook lifting.
- Crawler frame and "A" frame should also be extended before working.
- Jib boom can only be used crane operations.
- Main boom can only be used for crane operations when equipped with 6.0m~15.0m jib.
- All rated loads are based on structural strength factors.  
Make sure to prevent overloading.

## Jib rated lifting loads

(Unit: metric ton)

Boom length(m)	12.0										15.0								
	Jib length(m)		6.0		9.0		12.0		15.0		6.0		9.0		12.0		15.0		
	Offset angle	1.0	30°	1.0	30°	1.0	30°	1.0	30°	1.0	30°	1.0	30°	1.0	30°	1.0	30°		
Working radius(m)	~	10'	30'	10'	30'	10'	30'	10'	30'	~	10'	30'	10'	30'	10'	30'	10'	30'	
4.0	5.80									4.4mx 5.80									
4.5	5.80									5.80									
5.0	5.80	5.5mx 5.00								5.80									
6.0	5.80	5.00		6.6mx 5.00						5.80	5.00								
7.0	5.80	5.00	7.3mx 5.00	5.00				7.4mx 4.00		5.80	5.00	7.8mx 5.00	7.1mx 5.00						
8.0	5.80	5.00	5.00	5.00				4.00		5.80	5.00	5.00	5.00		4.00		2.60		
9.0	5.80	5.00	5.00	5.00	9.2mx 4.10	4.00			2.60	5.80	5.00	5.00	5.00	9.7mx 4.10	4.00		2.60		
10.0	5.80	5.00	5.00	5.00	4.10	4.00		10.9mx 3.20	2.60	5.80	5.00	5.00	5.00	4.10	4.00	11.4mx 3.20	2.60		
12.0	5.80	5.00	5.00	5.00	4.10	4.00	3.20	2.60		12.4mx 2.30	5.80	5.00	5.00	5.00	4.10	4.00	3.20	2.60	12.9mx 2.30
14.0	12.4mx 5.80	5.00	5.00	5.00	4.10	4.00	3.20	2.60	2.30	5.80	5.00	5.00	5.00	4.10	4.00	3.20	2.60	2.30	
16.0		5.00	5.00	5.00	4.10	4.00	3.20	2.60	2.30	15.0mx 5.80	5.00	5.00	5.00	4.10	4.00	3.20	2.60	2.30	
18.0		17.6mx 5.00	5.00	5.00	4.10	4.00	3.20	2.60	2.30		5.00	5.00	5.00	4.10	4.00	3.20	2.60	2.30	
20.0				5.00	4.10	4.00	3.20	2.60	2.30		5.00	5.00	5.00	4.10	4.00	3.20	2.60	2.30	
22.0					21.0mx 4.10	4.00	3.20	2.60	2.30		20.2mx 5.00	20.6mx 4.90	5.00	4.10	4.00	3.20	2.60	2.30	
24.0						23.2mx 4.00	3.20	2.60	2.30				23.0mx 4.25	23.6mx 4.10	4.00	3.20	2.60	2.30	
26.0								25.8mx 2.60	2.30						25.8mx 3.50	3.20	2.60	2.30	
28.0									27.0mx 2.30							26.6mx 3.20	2.60	2.30	
30.0																	28.4mx 2.60	28.6mx 2.30	

Boom length(m)	18.0										21.0								
	Jib length(m)		6.0		9.0		12.0		15.0		6.0		9.0		12.0		15.0		
	Offset angle	1.0	30°	1.0	30°	1.0	30°	1.0	30°	1.0	30°	1.0	30°	1.0	30°	1.0	30°		
Working radius(m)	~	10'	30'	10'	30'	10'	30'	10'	30'	~	10'	30'	10'	30'	10'	30'	10'	30'	
5.0	5.80									5.5mx 5.80									
6.0	5.80	6.5mx 5.00								5.80									
7.0	5.80	5.00		7.6mx 5.00						5.80	7.1mx 5.00								
8.0	5.80	5.00	6.3mx 5.00	5.00				6.4mx 4.00		5.80	5.00	6.3mx 5.00	6.2mx 5.00						
9.0	5.80	5.00	5.00	5.00				4.00		5.80	5.00	5.00	5.00		4.00		9.5mx 2.60		
10.0	5.80	5.00	5.00	5.00	10.3mx 4.10	4.00		2.60		5.80	5.00	5.00	5.00	10.8mx 4.10	4.00		2.60		
12.0	5.80	5.00	5.00	5.00	4.10	4.00	3.20	2.60		5.80	5.00	5.00	5.00	4.10	4.00	12.5mx 3.20	2.60		
14.0	5.80	5.00	5.00	5.00	4.10	4.00	3.20	2.60	13.4mx 2.30	5.80	5.00	5.00	5.00	4.10	4.00	3.20	2.60	2.30	
16.0	5.80	5.00	5.00	5.00	4.10	4.00	3.20	2.60	2.30	5.80	5.00	5.00	5.00	4.10	4.00	3.20	2.60	2.30	
18.0	17.6mx 5.70	5.00	5.00	5.00	4.10	4.00	3.20	2.60	2.30	6.40	5.00	5.00	5.00	4.10	4.00	3.20	2.60	2.30	
20.0		5.00	5.00	5.00	4.10	4.00	3.20	2.60	2.30	4.70	5.00	5.00	5.00	4.10	4.00	3.20	2.60	2.30	
22.0		4.45	4.45	4.45	4.10	4.00	3.20	2.60	2.30	20.2mx 4.65	4.35	4.35	4.35	4.10	4.00	3.20	2.60	2.30	
24.0		22.8mx 4.20	23.2mx 4.05	3.90	3.90	3.90	3.20	2.60	2.30		3.85	3.85	3.85	3.85	3.85	3.20	2.60	2.30	
26.0				25.7mx 3.40	3.35	3.35	3.20	2.60	2.30		25.4mx 3.40	25.8mx 3.30	3.30	3.30	3.30	3.20	2.60	2.30	
28.0					26.2mx 3.30	3.05	3.05	2.60	2.30				2.95	2.95	2.95	2.95	2.60	2.30	
30.0						28.4mx 2.95	29.2mx 2.80	2.60	2.30					28.2mx 2.90	28.8mx 2.80	2.65	2.65	2.60	2.30
32.0								31.0mx 2.55	2.30						31.0mx 2.50	31.8mx 2.30	2.35	2.30	
34.0																	33.8mx 2.25	2.00	

Boom length(m)	24.0										27.0								
	Jib length(m)		6.0		9.0		12.0		15.0		6.0		9.0		12.0		15.0		
	Offset angle	1.0	30°	1.0	30°	1.0	30°	1.0	30°	1.0	30°	1.0	30°	1.0	30°	1.0	30°		
Working radius(m)	~	10'	30'	10'	30'	10'	30'	10'	30'	~	10'	30'	10'	30'	10'	30'	10'	30'	
6.0	5.80									6.5mx 5.80									
7.0	5.80	7.6mx 5.00								5.80									
8.0	5.80	5.00		8.7mx 5.00						5.80	8.1mx 5.00								
9.0	5.80	5.00	9.3mx 5.00	5.00				9.5mx 4.00		5.80	5.00		9.2mx 5.00						
10.0	5.80	5.00	5.00	5.00	11.3mx 4.10	4.00		2.60		5.80	5.00	5.00	5.00	11.8mx 4.10	4.00		10.5mx 2.60		
12.0	5.80	5.00	5.00	5.00	4.10	4.00	13.0mx 3.20	2.60		5.80	5.00	5.00	5.00	4.10	4.00		2.60		
14.0	5.80	5.00	5.00	5.00	4.10	4.00	3.20	2.60	14.5mx 2.30	5.80	5.00	5.00	5.00	4.10	4.00	3.20	2.60	2.30	15.0mx 2.30
16.0	5.80	5.00	5.00	5.00	4.10	4.00	3.20	2.60	2.30	5.80	5.00	5.00	5.00	4.10	4.00	3.20	2.60	2.30	
18.0	5.30	5.00	5.00	5.00	4.10	4.00	3.20	2.60	2.30	5.20	5.00	5.00	5.00	4.10	4.00	3.20	2.60	2.30	
20.0	4.60	4.90	4.90	4.90	4.10	4.00	3.20	2.60	2.30	4.50	4.80	4.80	4.80	4.10	4.00	3.20	2.60	2.30	
22.0	4.00	4.30	4.30	4.30	4.10	4.00	3.20	2.60	2.30	3.90	4.20	4.20	4.20	4.10	4.00	3.20	2.60	2.30	
24.0	22.8mx 3.90	3.75	3.75	3.75	3.75	3.75	3.20	2.60	2.30	3.40	3.70	3.70	3.70	3.70	3.70	3.20	2.60	2.30	
26.0		3.25	3.25	3.25	3.25	3.25	3.20	2.60	2.30	25.4mx 2.95	3.15	3.15	3.15	3.15	3.15	3.15	2.60	2.30	
28.0		2.90	2.90	2.90	2.90	2.90	2.90	2.60	2.30		2.85	2.85	2.85	2.85	2.85	2.85	2.60	2.30	
30.0			28.4mx 2.85	2.60	2.60	2.60	2.60	2.60	2.30		2.50	2.50	2.50	2.50	2.50	2.50	2.50	2.30	
32.0				30.8mx 2.45	31.4mx 2.35	2.25	2.25	2.25	2.25		30.6mx 2.40	31.0mx 2.35	2.20	2.20	2.20	2.20	2.20	2.20	
34.0						33.6mx 2.00	1.95	1.95	1.95					33.4mx 1.90	1.85	1.85	1.85	1.85	

## Rated lifting loads

(Unit: metric ton)

Boom length(m) Working radius(m)	12.00	15.00	18.00	21.00	24.00	27.00	30.00	33.00	36.00	39.00	42.00	45.00	48.00	51.00
3.7	50.00	3.9m × 47.90												
4.0	48.90	47.00	4.4m × 41.60											
4.5	40.30	40.20	40.10											
5.0	33.80	33.70	33.60	33.50	5.5m × 28.70	5.9m × 25.65								
6.0	25.50	25.40	25.30	25.20	25.10	25.00	6.5m × 22.05							
7.0	20.40	20.30	20.20	20.10	20.00	19.90	19.80	19.70	7.6m × 17.00					
8.0	17.00	16.90	16.80	16.70	16.60	16.50	16.40	16.30	16.20	8.1m × 15.80	8.6m × 14.40			
9.0	14.50	14.40	14.30	14.20	14.10	14.00	13.90	13.80	13.70	13.60	13.50	9.1m × 13.15	9.8m × 11.40	
10.0	12.60	12.50	12.40	12.30	12.20	12.10	12.00	11.90	11.80	11.70	11.60	11.50	11.20	10.3m × 8.50
12.0	11.5m × 10.50	9.90	9.80	9.70	9.60	9.50	9.40	9.30	9.20	9.10	9.00	8.90	8.80	8.50
14.0		8.10	8.00	7.90	7.80	7.70	7.60	7.50	7.40	7.30	7.20	7.10	7.00	6.90
16.0		14.1m × 8.00	6.70	6.60	6.50	6.40	6.30	6.20	6.10	6.00	5.90	5.80	5.70	5.60
18.0			16.7m × 6.35	5.70	5.60	5.50	5.40	5.30	5.20	5.10	5.00	4.90	4.80	4.70
20.0				19.3m × 5.20	4.90	4.80	4.70	4.60	4.50	4.40	4.30	4.20	4.10	4.00
22.0					21.9m × 4.30	4.20	4.10	4.00	3.90	3.80	3.70	3.60	3.50	3.40
24.0						3.70	3.60	3.50	3.40	3.30	3.20	3.10	3.00	2.90
26.0							24.5m × 3.50	3.10	3.00	2.95	2.85	2.75	2.65	2.45
28.0								27.0m × 2.90	2.70	2.60	2.50	2.40	2.30	2.10
30.0									29.7m × 2.30	2.30	2.20	2.10	2.00	1.80
32.0										2.00	1.90	1.80	1.70	1.50
34.0										32.3m × 1.95	1.60	1.50	1.40	1.25
No. of Part Line	10	10	9	7	6	6	5	4	4	3	3	3	2	2

### Notes

- Above rated loads are based on firm level ground, within 78% of tipping load at any point 360° throughout and with front stability of 1.15 or more.
- Working radius is horizontal distance from center of rotation to a vertical line through the centerline of gravity of the load.
- The weight of the hook block and other lifting devices must be considered to be a part of the load.  
 50 ton hook block.....0.49ton  
 25 ton hook block.....0.35ton  
 15 ton hook block.....0.31ton
- Crawler frame and A frame(high gantry) should also be extended before working.
- When jib boom is fitted actual loads that can be lifted with the main hook block should reduce following weights from the above chart(the weights include that of the auxiliary hook block).

Jib boom length(m)	1.00	6.00	9.00	12.00	15.00
Weight to be deducted(ton)	0.30	0.75	0.95	1.20	1.45

- Depending on the number of part lines, rated lifting load is limited as follows.  
 1-part line.....up to 5.8 tons  
 2-part line.....up to 11.4 tons  
 3-part line.....up to 16.0 tons  
 4-part line.....up to 20.0 tons  
 5-part line.....up to 25.0 tons  
 6-part line.....up to 30.0 tons  
 7-part line.....up to 35.0 tons  
 8-part line.....up to 40.0 tons  
 9-part line.....up to 45.0 tons  
 10-part line.....up to 50.0 tons
- The hook block will not come down to ground level, if the rope part line is more than shown in above chart.

# Lifting magnet

CCH500-III

## ■ Lifting magnet crane rated lifting loads.

(Unit: metric ton)

Boom length(m) Working radius(m)	12.0	15.0	18.0	21.0
3.7	25.00	3.9m × 25.00		
4.0	25.00	25.00	4.4m × 25.00	
4.5	25.00	25.00	25.00	
5.0	25.00	25.00	25.00	25.00
6.0	22.95	22.85	22.75	22.65
7.0	18.35	18.25	18.15	18.05
8.0	15.30	15.20	15.10	15.00
9.0	13.10	13.00	12.90	12.80
10.0	11.30	11.20	11.10	11.00
12.0	11.5m × 9.45	8.90	8.80	8.70
14.0		7.30	7.20	7.10
16.0		14.1m × 7.20	6.00	5.90
18.0			16.7m × 5.70	5.10
20.0				19.3m × 04.60
No. of Part Line	5	5	5	5

### Notes

- Above rated loads are based on firm level ground within 78% of tipping load at any point 360° throughout and with front stability of 1.15 or more.
- Crawler frame and A frame(High gantry) should also be extended before working.
- The weight of the hook block, magnet and other lifting devices must be considered to be a part of the load.  
Hook block weight.  
35ton.....0.35ton  
25ton.....0.35ton  
15ton.....0.31ton
- Depending on the number of part line, rated lifting load is limited as follows.  
2-part line.....up to 11.4tons  
3-part line.....up to 16.0tons  
4-part line.....up to 20.0tons  
5-part line.....up to 25.0tons

## General dimensions (Unit : mm)

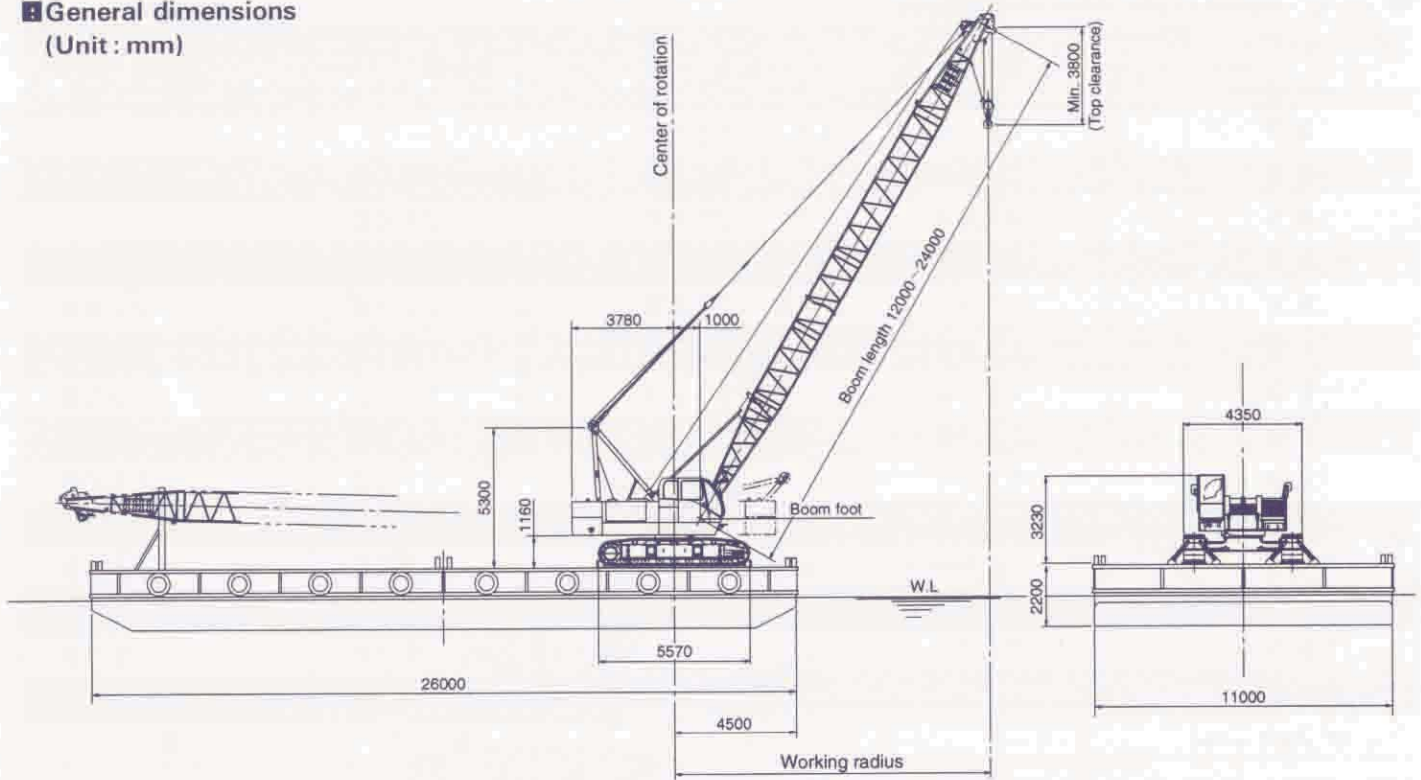

Above figure is for reference when mounted crawler crane on pontoon as floating crane.

## Pontoon mounted crane specifications

Max.lifting capacity(metric ton) × working radius(m)	35 × 4.8	
Max.boom length	24m	
Rope speed	Main drum hoist/lowering	*100/70·50/35m/min
	Aux.drum hoist/lowering	*100/70·50/35m/min
	Boom drum hoist/lowering	*60m/min
Part line	Hook Block capacity(ton) × part line (m)	35 × 7 5.8 × 1
	Boom drum hoist/lowering	12
	Counterweight(ton)	16
Total operating weight with 12 m boom (including crawler fixing device)(ton)	50.0	
Average ground bearing pressure(kg/cm <sup>2</sup> )	0.64	

\* : The rope speed changes depending on the load.

## Wire rope

Place of use	Rope diameter(mm)/Guaranteed strength(ton)	Rope type
Main drum	20.0/30.0	A
Aux.drum	20.0/30.0	A
Boom hoist	16.0/21.8	B
Boom suspension	31.5/74.9	A

Ropetype A : 6 × Fi(29)IWRC regular Z lay

B : 6 × WS(31)T IWRC regular Z lay

Length of wire rope to be decided according to the ordered boom length.

# Pontoon mounted crane

CCH500-3II

## ■ Pontoon mounted crane rated lifting loads.(Throughout 360°)

(Unit : metric ton)

Boom length(m) Working radius(m)	12.0	15.0	18.0	21.0	24.0
3.7	35.00	3.9m × 30.00			
4.0	35.00	30.00	4.4m × 25.00		
4.5	4.8m × 35.00	30.00	25.00		
5.0	33.80	5.3m × 30.00	25.00	25.00	5.5m × 25.00
6.0	25.50	25.40	6.1m × 25.00	25.00	25.00
7.0	20.40	20.30	20.20	20.10	20.00
8.0	17.00	16.90	16.80	16.70	16.60
9.0	14.50	14.40	14.30	14.20	14.10
10.0	12.60	12.50	12.40	12.30	12.20
12.0	11.5m × 10.50	9.90	9.80	9.70	9.60
14.0		8.10	8.00	7.90	7.80
16.0		14.1m × 8.00	6.70	6.60	6.50
18.0			16.7m × 6.35	5.70	5.60
20.0				19.3m × 5.20	4.90
22.0					21.9m × 4.30
<b>No. of part Line</b>	7	6	5	5	5

### Notes

- The working radius is horizontal distance from center of rotation to vertical line through the center line of gravity of the load.
- The weight of the hook block and other lifting devices must be considered to be a part of the load.
  - 50ton hook block.....0.49ton
  - 35ton hook block.....0.35ton
  - 15ton hook block.....0.31ton
  - 5.8ton hook block.....0.12ton
- Do not exceed 3° of trim angle of pontoon on loaded condition.
- Depending on the number of part lines, rated lifting is limited as follows.
  - 1-part line.....up to 5.8tons
  - 2-part line.....up to 11.4tons
  - 3-part line.....up to 15.0tons
  - 4-part line.....up to 20.0tons
  - 5-part line.....up to 25.0tons
  - 6-part line.....up to 30.0tons
  - 7-part line.....up to 35.0tons
- When 1 m jib installed, actual load that can be lifted with main hook block should be reduced 0.3 ton from above chart.
- The 1m jib lifting load should be reduced(0.3ton+main hook block weight)from above chart. However do not exceed 5.8tons.
- Bucket operation can not be performed by 1 m jib.
- Maximum boom length is 18m on bucket work.
- The rated lifting load is 5ton on bucket work.
  - Do not exceed 5ton for"bucket weight+load" during bucket work.

#### ■ Optional equipment

- Moment limiter(overload prevention)
- Yellow rotary light
- Wireless phone
- Bullhorn
- Combustion type heater
- Defroster
- Spark arrester
- Digging depth/Lift indicator (with bucket opening angle indicator)
- Electrical type level indicator
- Level vail
- Fire extinguisher
- Monitor TV(watching rear,left and drum)
- Engine throttle pedal
- Drum rotation roller
- Drum mirror
- Catwalk
- Large size tool box(installed on car body)
- Third drum(with clutch and brake:type A)
- Third drum(automatic brake:typeB)
- Reeving winch
- Hydraulic power take off (A Spec.) $300\text{kg}/\text{cm}^2 \times 225 \text{ l} / \text{min}$
- Hydraulic power take off (B Spec.) $210\text{kg}/\text{cm}^2 \times 125 \text{ l} / \text{min}$
- Anemometer
- Drum light
- Work light on boom
- Work light for rear direction
- Rope guard for boom top surface
- 3m,6m,9m,insert boom with pendant rope
- 6m basic jib boom
- 3m,6m,jib insert boom with pendant rope
- 1m jib
- 35ton hook block(3sheaves)
- 25ton hook block(3sheaves)
- 15ton hook block(1sheave)
- 5.8ton hook block
- Fulcrum plate for raising of attachment (standard accessory for longer than 39m boom)
- Crawler frame fixing device to pontoon
- Airconditioner