

**AVAILABLE
FOR HIRE**



IHC FUNDEX CPE15 Accelerated Impact Hammer

On a Hyundai HX330L with Leader

Available for Hire Nationwide

Contact the Rental Team for rates and availability

Tel: 01789 292227

E-mail: rental@agd-equipment.co.uk

For more information about AGD please visit www.agd-equipment.co.uk

Hyundai HX330L

Engine Make / Model	Cummins QSL9
Re-Filling	Litre
Fuel Tank	600
Engine Coolant	55
Engine Oil	30
Swing Device	11
Final Drive (each Tank)	7.8
Hydraulic Tank	414
DEF/AdBlue	42.5
Gradeability	35° (70%)



Transport Weight (Ex Attachments) (Kg)	34,450
Operating Weight including CPE15 (Kg)	37,750

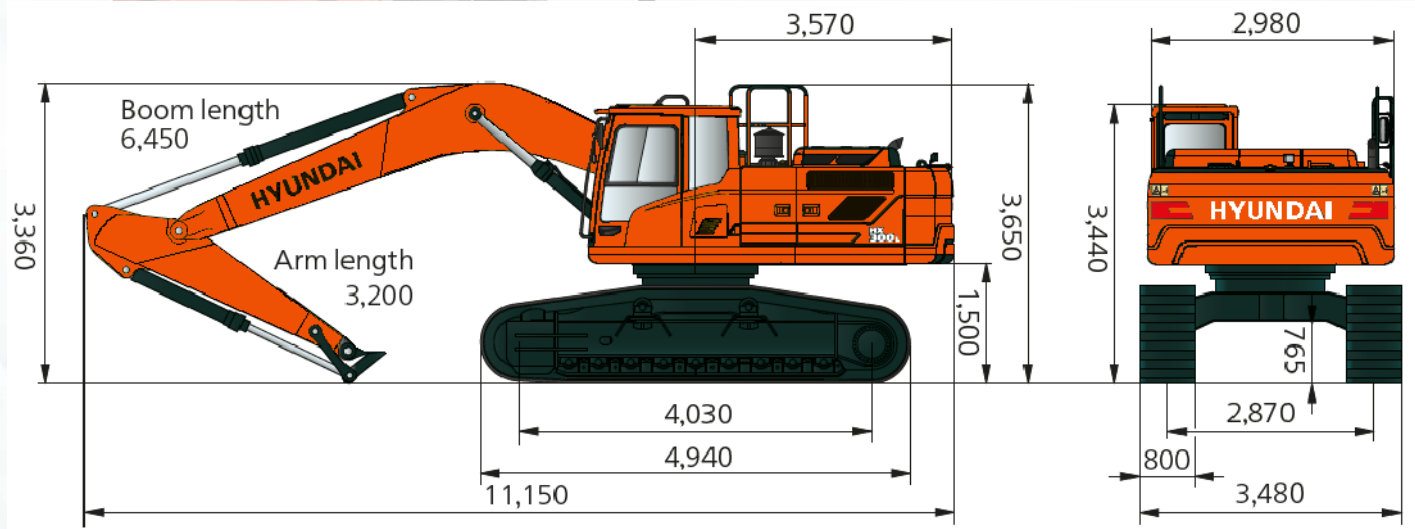

IHC Fundex CPE15 Including Leader

Max Energy	kNm	15
Drop Height	mm	40-1,000
Leader Stroke	mm	2,000
Blow Rate	bl/min	40-100
Ram	kg	1,000
Total Weight	kg	1,960
Oil Flow	l/min	85
Oil Pressure	bar	120
Width	mm	620
Length	mm	787
Height	mm	4,730
Max Tubular Pile	mm	406Ø
Max Concrete Pile	mm	250
Max Timbar Pile	mm	250
Max Sheet Pile "Z"	mm	700
Max Sheet Pile "U"	mm	750