

CH 450

Self-Erecting Hydraulic Piling Rig



CH 450

MULTIPURPOSE PILING RIG

The CH 450 is the winning solution for job sites of short duration that require frequent operations of transport, setting up and dismantling.

Truly self-erecting. The machine is entirely autonomous and self-erecting, and can be transported in one piece/fully assembled with the rotary head and Kelly bar installed. Once on site, the machine is easily off loaded from the truck and set up without the need for crane service.

Wide range of drilling technologies. The CH 450 can be offered in CPD (cylinder pulldown) and WPD (winch pulldown) configuration. The innovative rotary head design adopted by Comacchio allows for the use of Kelly bars of various diameters, including HD (heavy duty) bars and XHD (extra heavy duty) bars, up to a maximum length of 14 m, with minor changes on the rotary head.

The unique design of the CH 450 adapts to a **wide range of drilling technologies** that include:

BP (Bored Piles) uncased bored piles excavated by dry method or stabilized by fluid overpressure;

CBP (Cased Bored Piles) bored piles with casing installation by rotary drive or optionally by hydraulic casing oscillator;

CFA (Continuous Flight Auger) piles that are drilled uncased by the use of a continuous hollow auger stem;

DP (Displacement Piles) piles installed without soil removal by advancing a special tool into the ground that causes the soil to be displaced radially and vertically

SM (Soil Mixing) piles constructed by mixing and partly replacing the existing soils with grout using a soil mixing tool;

LDTH (Large DTH) piles installed with DTH method using bits of a larger diameter than standard bits;

MP (Micropiles) installed using conventional air-flush rotary drilling.

The CH 450 can be offered in two different LHR (low head room) configurations, designed for the construction of bored piles in challenging access sites.





	m.s.	i.s.	BP (Bored Piles)		CBP (Cased Bored Piles)	
Max. pile diameter CPD	mm	ft-in	2.000 ⁽¹⁾	6' 7" ⁽¹⁾	1.500	4' 11"
Max. pile diameter WPD	mm	ft-in	2.000 ⁽¹⁾	6' 7" ⁽¹⁾	1.300	4' 3"
Max. pile depth CPD	m	ft-in	56,60 ⁽²⁾	185' 8" ⁽²⁾	56,60 ⁽³⁾	185' 8" ⁽³⁾
Max. pile depth WPD	m	ft-in	62,90 ⁽²⁾	206' 4" ⁽²⁾	62,90 ⁽²⁾	206' 4" ⁽²⁾
Pile diam with casing oscillator min.-max.	mm	ft-in	-		600 - 1.200	1' 11" - 3' 11"

(1) tool below mast.

(2) using self mounting kelly bar.

(3) open hole (uncased) depth.

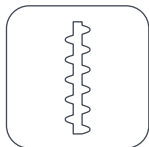

	m.s.	i.s.	CFA (Continuous Flight Auger)	
Max. pile diameter	mm	ft-in	1.000	3' 3"
Max. pile depth (CFA/WPD)	m	ft-in	14 + 7 = 21	45' 11" + 22' 11" = 68' 10"
Max. pile depth (CFA T4)	m	ft-in	16,5 + 6 = 22,5	54' 2" + 19' 8" = 73' 10"
Max. pile depth (CFA T4XL)	m	ft-in	18 + 6 = 24	59' 1" + 19' 8" = 78' 9"

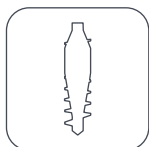

	m.s.	i.s.	DP (Displacement Piles)	
Max. pile diameter	mm	ft-in	450	1' 5"
Max. pile depth	m	ft-in	13,5 + 8,5 = 22	44' 3" + 27' 11" = 72' 2"



	m.s.	i.s.	SM (Soil Mixing)	
Pile diameter	mm	ft-in	400 - 2.000 ⁽⁴⁾	1' 4" - 6' 7" ⁽⁴⁾
Max. pile depth	m	ft-in	13,5 + 8,5 = 22	44' 3" + 27' 11" = 72' 2"

(4) according to the soil conditions.



	m.s.	i.s.	LDTH (Large DTH)	
Max. pile diameter	mm	ft-in	1.000	3' 3"
Max. pile depth	m	ft-in	Approx. 50 - 60 ⁽⁵⁾	164' - 196' ⁽⁵⁾

(5) max. depth is upon drill string weight.



	m.s.	i.s.	MP (Micropiles)	
Max. pile diameter	mm	ft-in	610	24"
Stroke of rotary head	mm	ft-in	14.500	47' 6"

CH 450

Technical Data

Undercarriage		m.s.	i.s.				
Type	-	Variable gauge, telescoping side frames					
Removable tracks	-	Triple grouser					
Track shoe width	mm	ft-in	600	1' 11"	800	2' 8"	
Track shoe type	-	Triple grouser					
Overall width (retracted side frames)	mm	ft-in	2.550	8' 4"	2.950	9' 8"	
Overall width (extended side frames)	mm	ft-in	4.000	13' 2"	4.200	13' 9"	
Overall length	mm	ft-in		4.925	16' 1"		
Centre idler to centre sprocket	mm	ft-in		4.100	13' 5"		
Upperframe							
Width	mm	ft-in		2.550	8' 4"		
Operators' cabin	-	TOPS & FOPS-1 certified, 980 mm [3' 3"] wide					
Control system type	-	CAN-BUS					
User interface	-	12" Touch Screen					
Tail swing radius	mm	ft-in		3.865	12' 8"		
Diesel Engine		<i>High Tech Line</i>					
Make and model	-	Cummins B6.7		Cummins QSB6.7			
Emission certification	-	EU stage V / US EPA Tier 4f			EU stage IIIA / US EPA Tier 3		
Aspiration	-	Turbocharged and charge air cooled					
Power rating (2.000 rpm)	kW	hp	209	284	201	274	
Displacement	cc	in ³		6.700	408		
Fuel tank	l	gal		500	135		
Sound pressure level in cabin (EN 16228-1, Annex B)	-	LP _A 82 dB (A)					
Sound Power level (2000/14/EC - EN 16228-1, Annex B)	-	LW _A 108 dB (A)					
Hydraulic System							
Main pumps flow	l/min	gal/min		2 x 214	2 x 56.5		
Service pump flow	l/min	gal/min		160	42.3		
Hydraulic oil tank capacity	l	gal		600	158		
Main Winch							
Type	-	Controlled descent					
1 st layer line pull	kN	lbs		160	35,970		
1 st layer rope speed	m/min	ft/min		75	246'		
Rope diameter	mm	in		24	1 ⁵ / ₁₆ "		
Rope layers	-	2					
FEM classification	-	M6-L3-T5					
Service Winch							
Type	-	Controlled descent			Free fall		
1 st layer line pull	kN	lbs		72	16,200		
1 st layer rope speed	m/min	ft/min	55	180'		49	161'
Rope diameter	mm	in		18	1 ¹ / ₈ "		
Rope layers	-	3			4		
FEM classification	-	M5-L2-T5			M6-L3-T5		

CH 450

Rotary Head

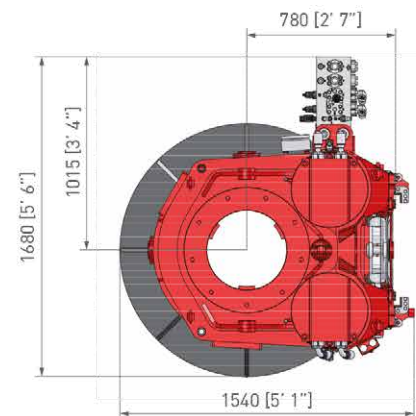
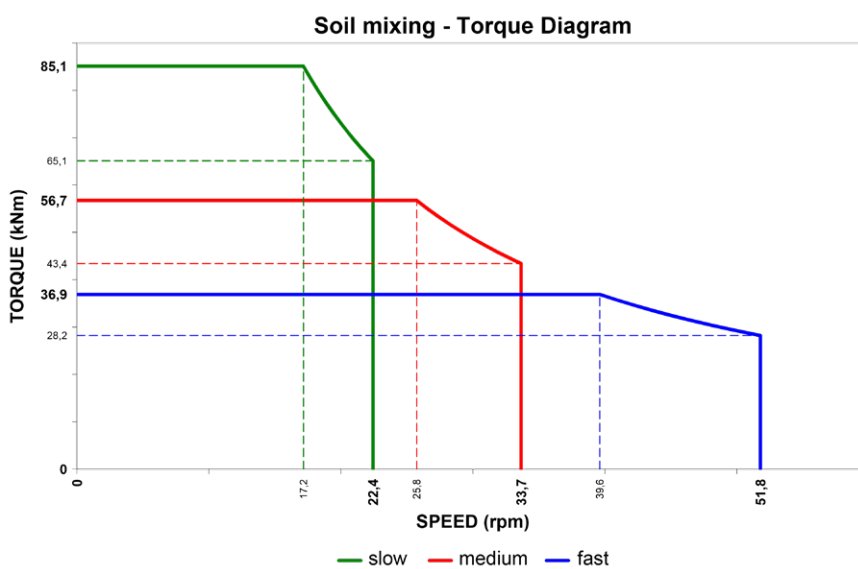
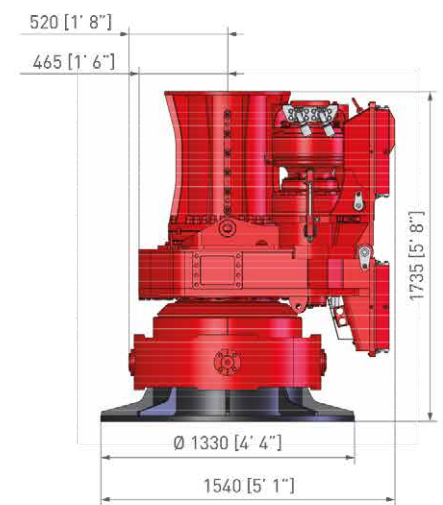
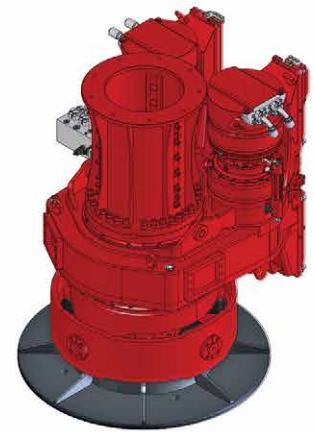
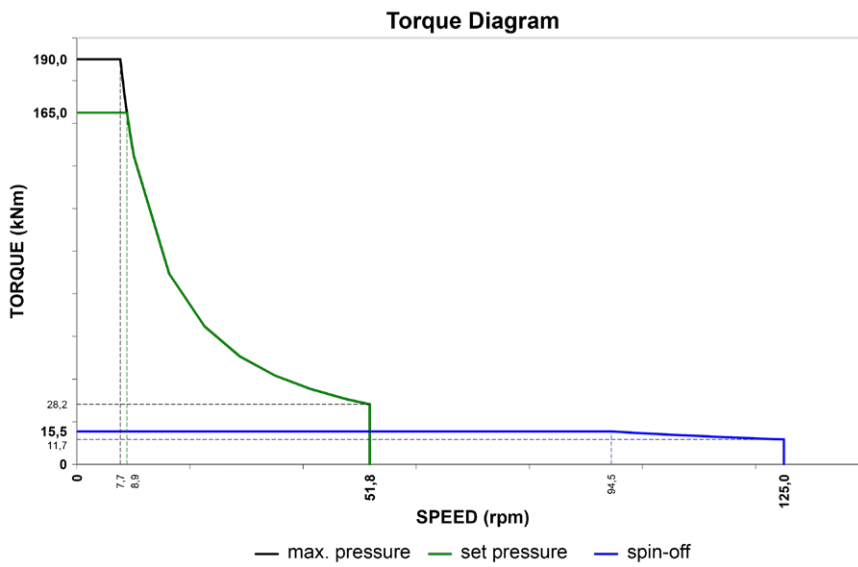

Rotary Head	m.s.	i.s.	CR 19	
Nominal max. torque	kNm	lbf-ft	190 at 33 MPa	140,000 at 4,800 psi
Max. torque	kNm	lbf-ft	165 at 28,5 MPa	121,700 at 4,130 psi
Max. drilling speed	rpm		51,8	
Hydraulic power	kW	hp	155	208
Spin-off speed	rpm		125	
Replaceable drive sleeve	-		Yes	
Replaceable drive keys	-		Yes	

CH 450

Options and Accessories

Standard equipment

Main winch with special grooving	Engine diagnostic panel
Hoist and lowering limit switches on main and service ropes	Transport securing lugs on crawler unit
Swivel for main rope	Work lights
Service rope parking point	Electric refuelling pump and hydraulic oil refilling
Mast inclination measurement on X & Y axes (digital and analog display)	Diagnostic panel for hydraulic, electrical and electronic functions
Automatic vertical mast alignment	Front and top cabin protective grate (FOPS-1 certified)
Depth measuring device on main winch	Radio CD player
Rpm measuring device on rotary	Phone charger
Crowd pressure setting	CCS Comacchio Controlling System
Oscillator attachment brackets	Spinoff and Shaker tool dump systems
Heating & air conditioning system	Rotary auto speed management & interactive multiple gear
Emergency mode of operation for engine	Tool box

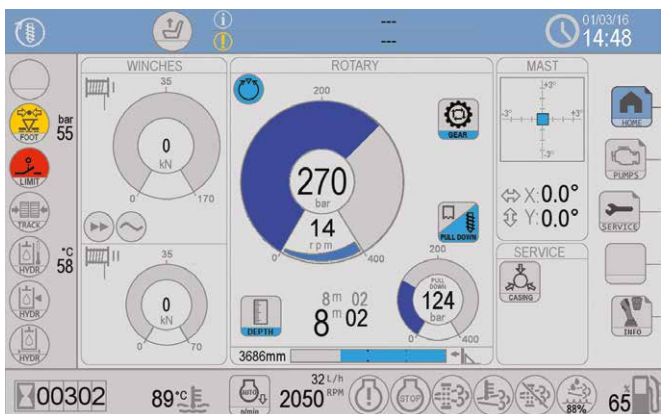

CCS: Home page

Optional equipment

Biodegradable oil	Welding equipment & generator
Freefall auxiliary winch	Air compressor kit
Main and aux winch load cells	Washing kit
Swivel for auxiliary rope	Videocamera set
Central lubrication system	Prearrangement for casing oscillator
Automatic lubrication kit for rotary sliding guides	Casing oscillator
CFA cleaner (star or hydraulic type)	Vibratory equipment for steel cage
Flange for bucket opening	Data logger
Cardan joint	ComNect system
Flange for casing driving	

CE conformity kit

Machine travel remote radio control	Video cameras set
Main and aux winch load cells	CFA cleaner
Side walkways w/handrails	Rubber strip on auger guide



CH 450

Kelly bars

Comacchio Innovative Kelly bar system

Three bar sizes are available with minor changes on the rotary head.

Kelly bar sizes	m.s.	i.s.	Outer diameter	
L (standard)	mm	ft-in	355	1' 2"
HD (Heavy Duty)	mm	ft-in	368	1' 3"
XHD (Extra Heavy Duty)	mm	ft-in	394	1' 4"

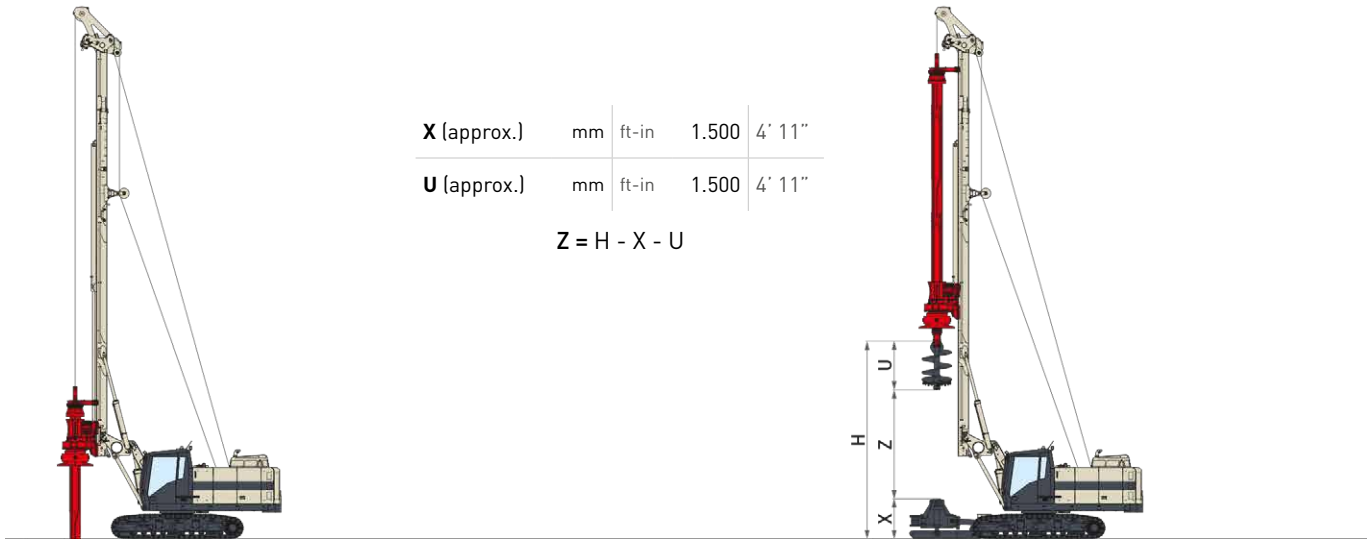

Depth	Kelly Bars				WPD				CPD				
	N.	Length		Weight ⁽¹⁾		Depth		H ⁽⁴⁾		Depth		H ⁽⁴⁾	
		(m)	(ft-in)	(kg)	(lbs)	(m)	(ft-in)	(m)	(ft-in)	(m)	(ft-in)	(m)	(ft-in)
Locking or friction	4	8	26' 2"	4.400	9,700	28,40	93' 2"	9,05	29' 8"	27,10	88' 10"	7,30	23' 11"
	4	9	29' 5"	4.800	10,600	32,40	106' 3"	8,05	26' 4"	31,10	102' 0"	7,30	23' 11"
	4	10,5	34' 4"	5.500	12,100	38,40	125' 11"	6,55	21' 5"	37,10	121' 8"	6,55	21' 5"
	4	12	39' 4"	6.100	13,400	44,40	145' 8"	5,05	16' 6"	43,10	141' 4"	5,05	16' 6"
	4	12,5	41'	6.300	13,900	46,40	152' 2"	4,55	14' 11"	45,10	147' 11"	4,55	14' 11"
	4	13 ⁽²⁾	42' 6" ⁽²⁾	6.500	14,300	48,40	158' 9"	4,05	13' 3"	47,10	154' 6"	4,05	13' 3"
	4	13,5 ⁽²⁾	44' 3" ⁽²⁾	6.700	14,800	50,40	165' 4"	3,55	11' 7"	49,10	161' 1"	3,55	11' 7"
	4	14 ^{(2)/(3)}	46' ^{(2)/(3)}	6.900	15,200	52,40	171' 10"	3,05	10' 0"	51,10	167' 7"	3,05	10' 0"
Friction	5	8	26' 2"	5.000	11,000	35,40	116' 1"	9,05	29' 8"	34,10	111' 10"	7,30	23' 11"
	5	9	29' 5"	5.500	12,000	40,40	132' 6"	8,05	26' 4"	39,10	128' 3"	7,30	23' 11"
	5	10,5	34' 4"	6.100	13,500	47,90	157' 1"	6,55	21' 5"	46,60	152' 10"	6,55	21' 5"
	5	12	39' 4"	6.800	15,000	55,40	181' 9"	5,05	16' 6"	54,10	177' 5"	5,05	16' 6"
	5	12,5	41'	7.100	15,600	57,90	189' 11"	4,55	14' 11"	56,60	185' 8"	4,55	14' 11"
	5	13 *	42' 6" ⁽²⁾	7.300	16,000	60,40	198' 1"	4,05	13' 3"	59,10	193' 10"	4,05	13' 3"
	5	13,5 *	44' 3" ⁽²⁾	7.500	16,500	62,90	206' 4"	3,55	11' 7"	61,60	202' 1"	3,55	11' 7"
	5	14 ^{(2)/(3)}	46' ^{(2)/(3)}	7.700	16,900	65,40	214' 6"	3,05	10' 0"	64,10	210' 3"	3,05	10' 0"

(1) Weight refers to Ø 368,3 mm [1' 3"] HD version (2) Non self-mounting in CPD version
(3) Non self-mounting in WPD version (4) Max. height of bottom kelly pin above ground

CH 450

Casing Oscillator Arrangement

WPD

CPD

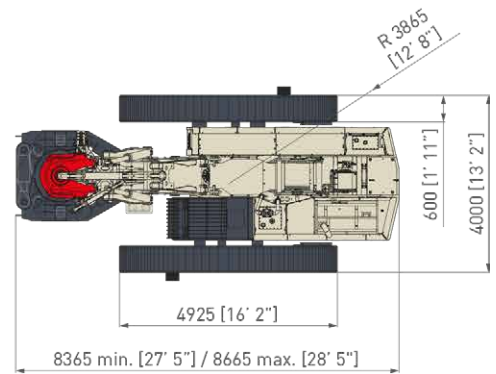
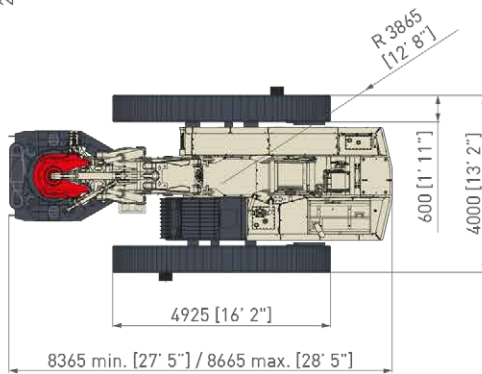
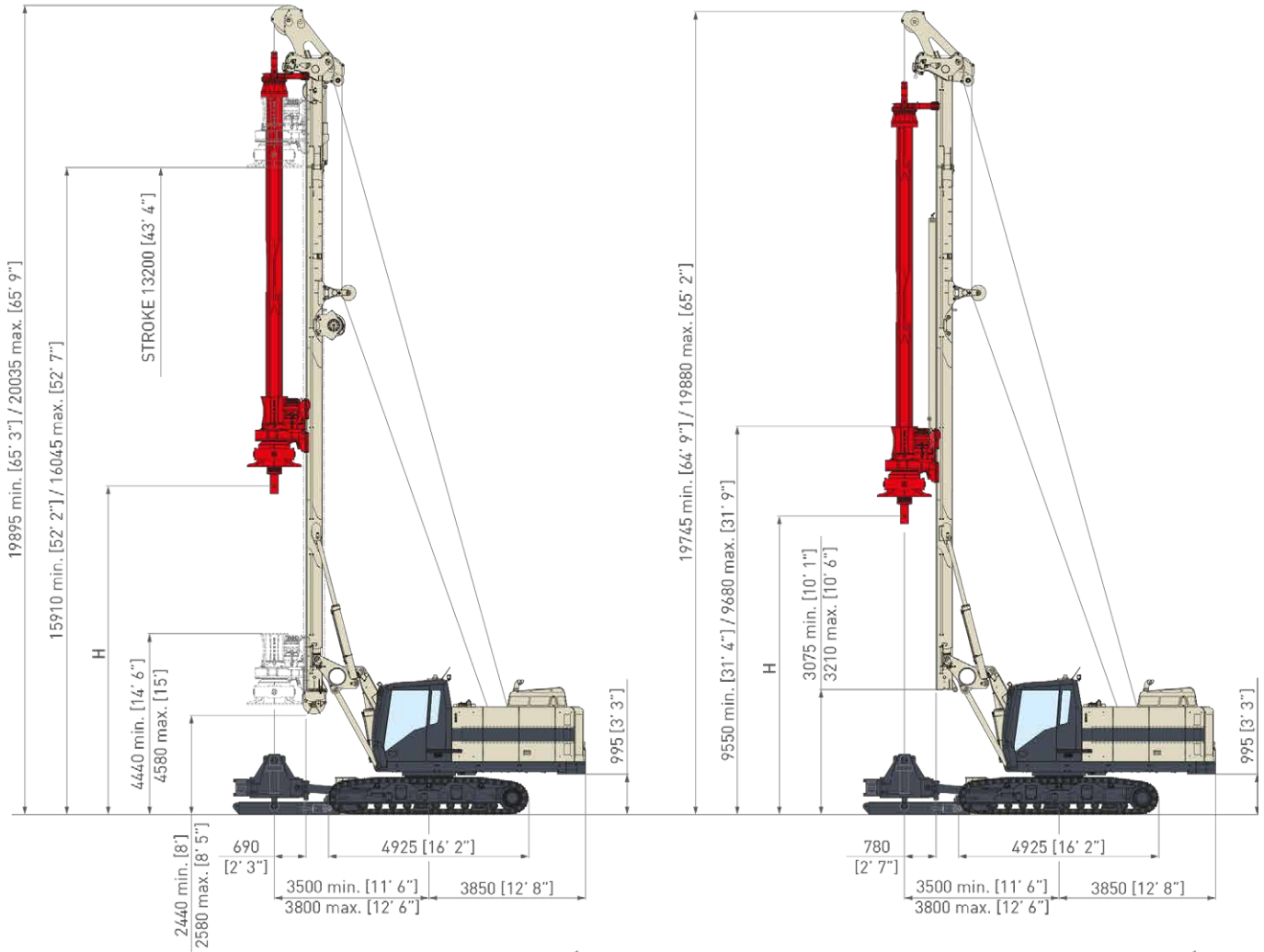

CH 450 - WPD

Overall dimensions

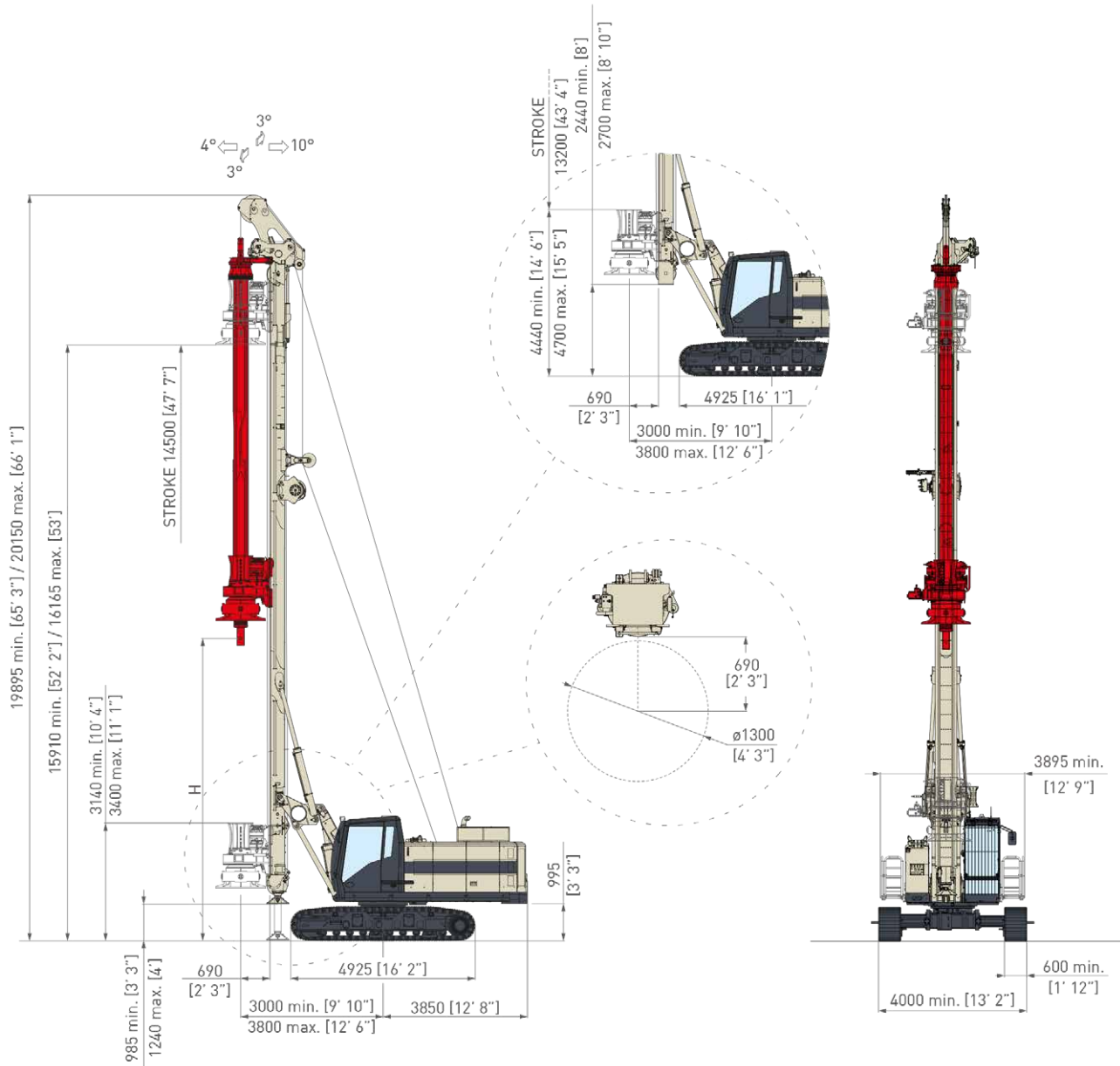

WPD (Winch Pull Down)

	m.s.	i.s.		
Stroke c/w mast foot	mm	ft-in	14.500	47' 7"
Stroke c/w lower reeving box	mm	ft-in	13.200	43' 4"
Max. pull up force	kN	lbs	240	53,950
Max. pull down force	kN	lbs	240	53,950
Speed down	m/min	ft/min	36	118'
Max. pile diameter	mm	ft-in	1.300 - 2.000 ⁽¹⁾	4' 3" - 6' 7" ⁽¹⁾
Operating weight w/o tool	kg	lbs	44.800 ⁽²⁾	98,800 ⁽²⁾

Notes

(1) with - without bottom mast element.

(2) c/w 4 x 9 m [4 x 29' 6"] long 368 mm [14" 1/2] dia. Kelly bar; rotary c/w bucket opening flange.



CH 450 - CPD

Overall dimensions

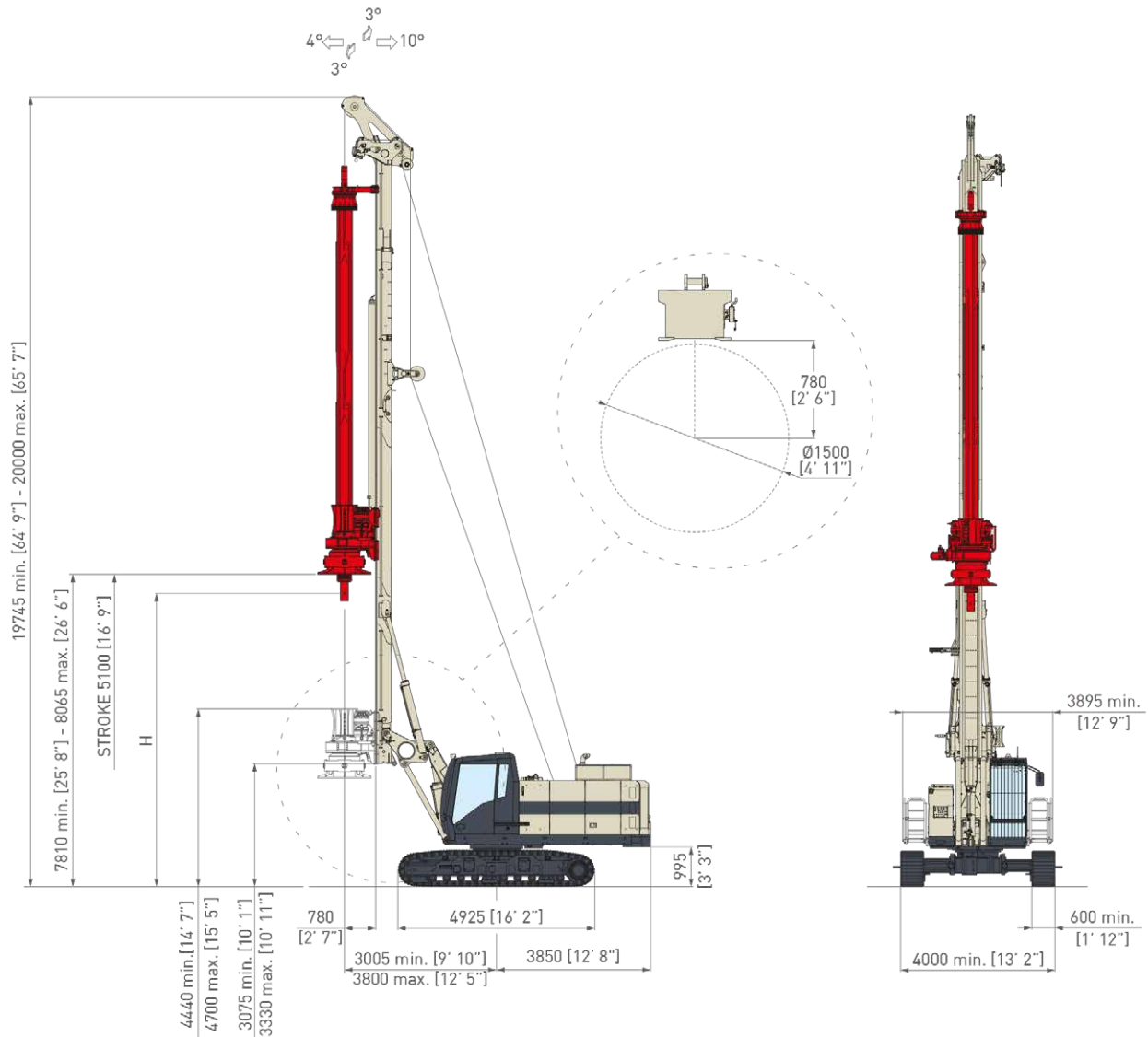

CPD (Cylinder Pull Down)

	m.s.	i.s.		
Stroke	mm	ft-in	5.100	16' 9"
Max. pull up force	kN	lbs	226	50,800
Max. pull down force	kN	lbs	204	45,860
Speed down	m/min	ft/min	20 - 21	65' 7" - 68' 11"
Max. pile diameter	mm	ft-in	1.500 ⁽¹⁾ / 1.800 ⁽²⁾ - 2.000 ⁽³⁾	4' 11" ⁽¹⁾ / 5' 11" ⁽²⁾ - 6' 7" ⁽³⁾
Operating weight w/o tool	kg	lbs	43.100 ⁽⁴⁾	95,000 ⁽⁴⁾

Notes

(1) tool in front of mast, standard CPD version.

(2) tool in front of mast, LHR CPD version.

(3) tool below mast, standard CPD version.

(4) c/w 4 x 9 m (4 x 29'6") long 368 mm (14" 1/2) dia. Kelly bar; rotary c/w bucket opening flange.



CH 450

COMACCHIO

CH 450 - CFA

Overall dimensions

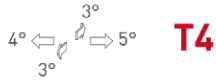

T4

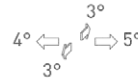

T4 XL - XXL

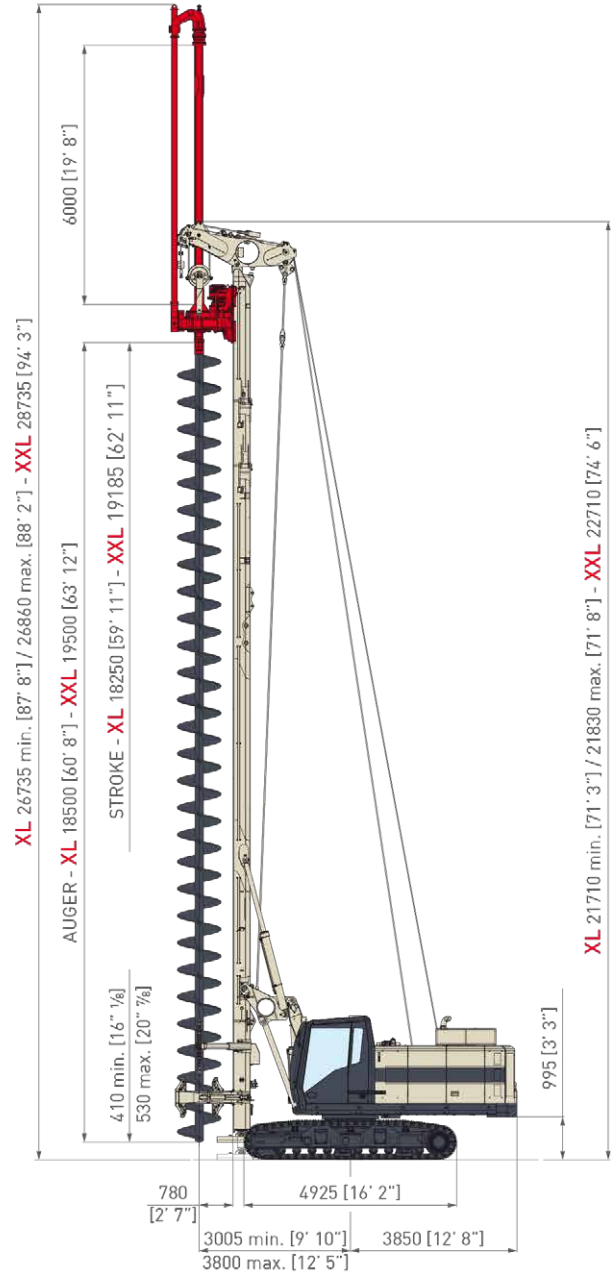
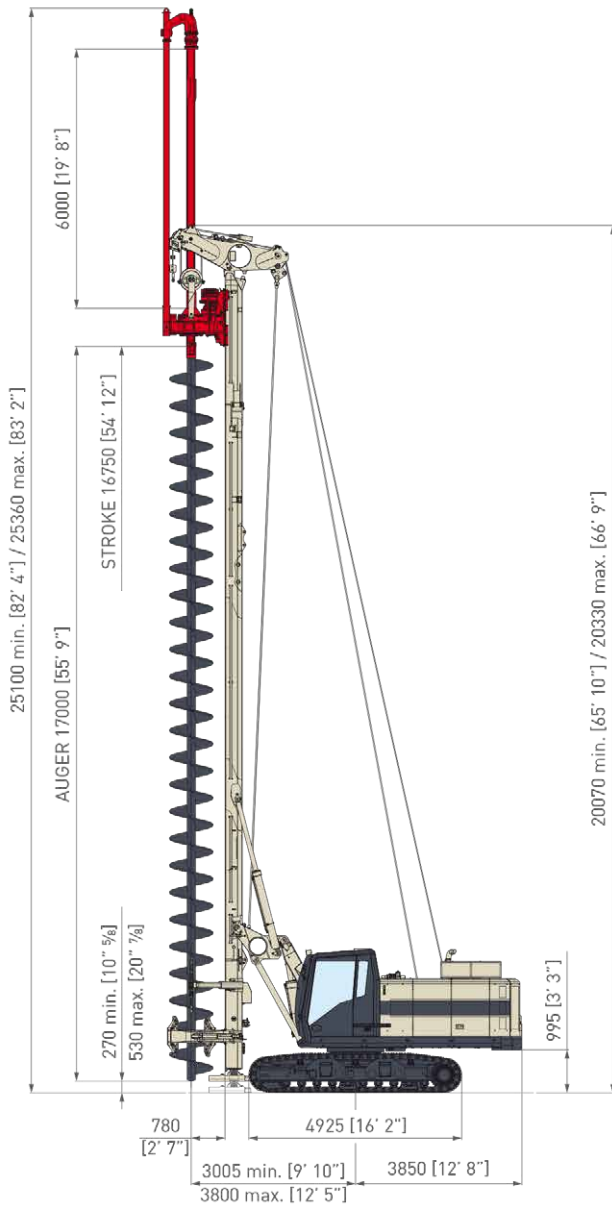

CFA	m.s.	i.s.	T4		T4 XL		T4 XXL	
Max. pile diameter	mm	ft-in	1.000	3' 3"	1.000	3' 3"	1.000	3' 3"
Max. length of augers	m	ft-in	17	55' 9"	18,5	60' 8"	19,5	63' 11"
Max. length of auger extension	m	ft-in	6	19' 8"	6	19' 8"	6	19' 8"
Max. pile depth	m	ft-in	16,5 + 6 = 22,5	54' 2" + 19' 8" = 73' 10"	18 + 6 = 24	59' 1" + 19' 8" = 78' 9"	19 + 6 = 25	62' 4" + 19' 8" = 81' 12"
Extraction force	kN	lbs	480	107,900	480	107,900	480	107,900
Crowd force on auger (optional)	kN	lbs	45	10,200	45	10,200	45	10,200
Operating weight w/o tool	kg	lbs	42.500	93,700	43.500	95,900	43.700	96,300



CH 450 - CFA/WPD

Overall dimensions

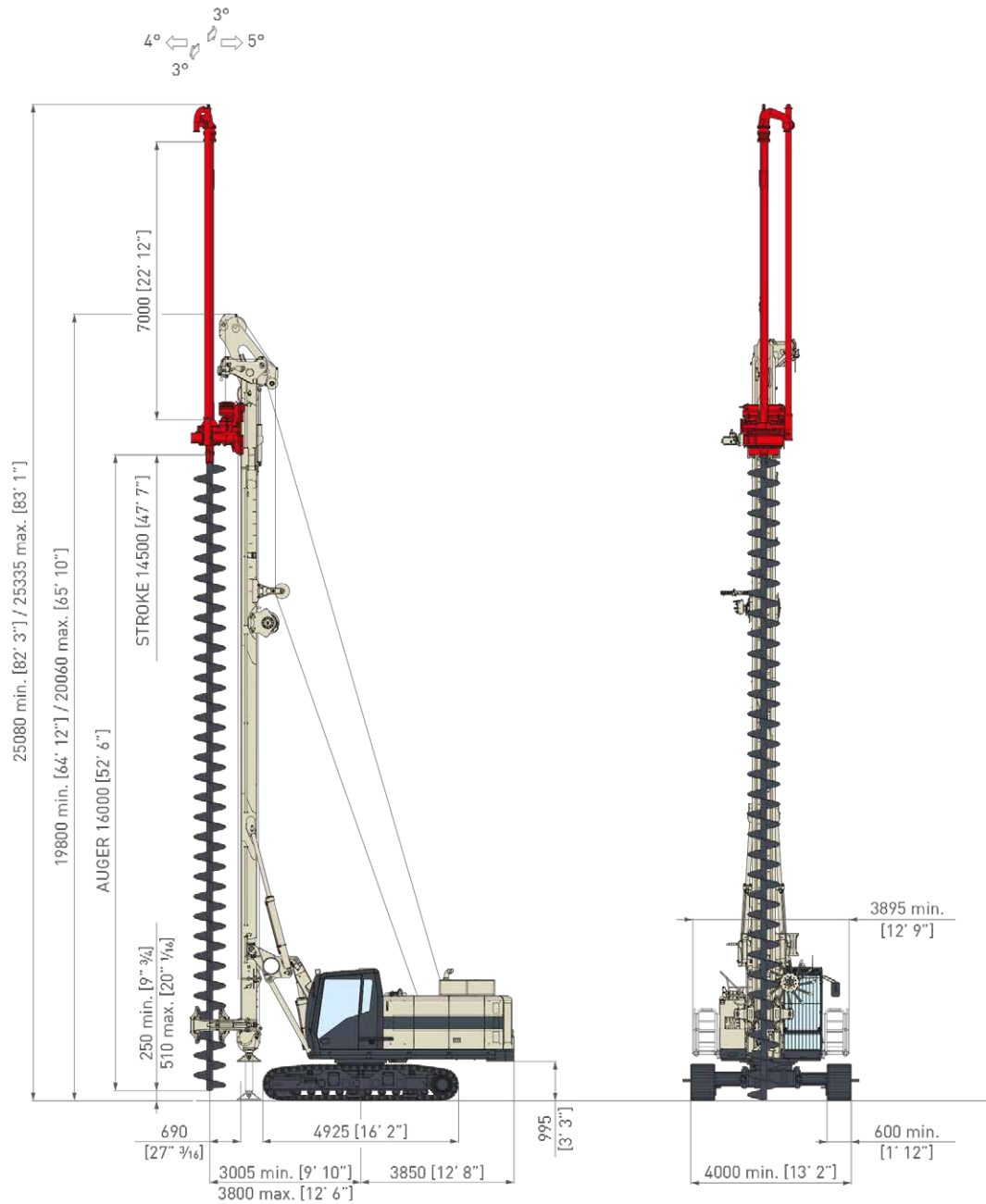

CFA	m.s.	i.s.	CFA/WPD (Quick Conversion CFA)	
Max. pile diameter	mm	ft-in	1.000	3' 3"
Max. length of augers	m	ft-in	16	52' 6"
Max. length of auger extension	m	ft-in	7	23'
Max. pile depth	m	ft-in	14 + 7 = 21	46' + 23' = 69'
Extraction force	kN	lbs	330	74,200
Crowd force on auger	kN	lbs	140	31,470
Operating weight w/o tool	kg	lbs	41.500	91,500
Max. drill string weight	kg	lbs	8.000	17,600



CH 450 - DP/SM

Overall dimensions

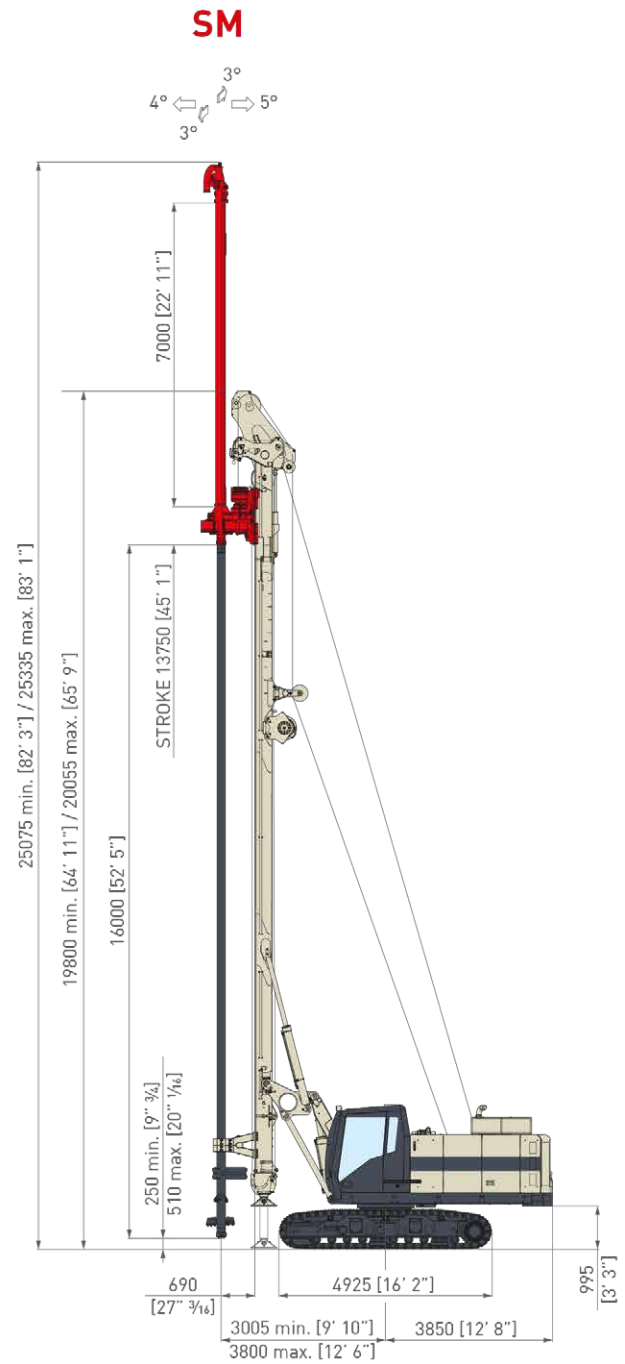
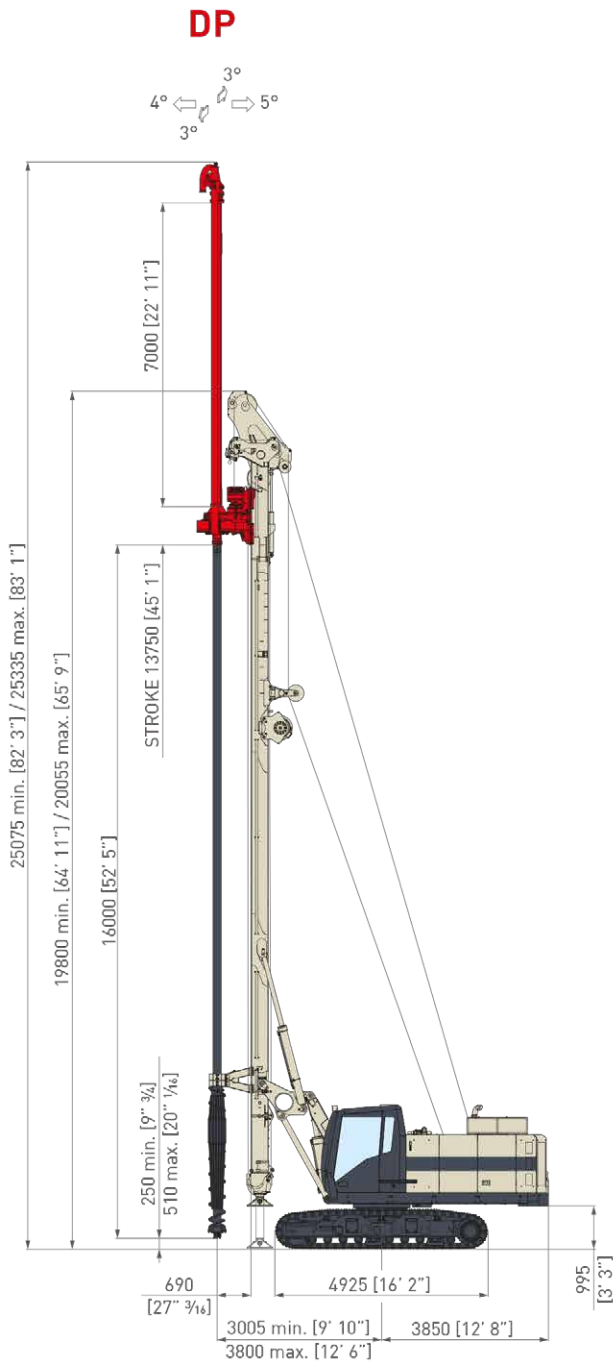

WPD (Winch Pull Down) / DP-SM	m.s.	i.s.	DP (Displacement Piles)		SM (Soil Mixing)	
Max. pile diameter	mm	in	400	16"	400 - 2000 ⁽¹⁾	16" - 6' 7" ⁽¹⁾
Max. drill string length	m	ft-in		16	52' 6"	
Max. length of drill string extension	m	ft-in		8,5	27' 11"	
Max. pile depth	m	ft-in		13,5 + 8,5 = 22	44' 3" + 27' 11" = 72' 2"	
Extraction force	kn	lbs		330	74,200	
Max. pull down force	kN	lbs		240	53,954	
Operating weight w/o tool	kg	lbs		41.500	91,500	

Note

(1) according to the soil conditions.

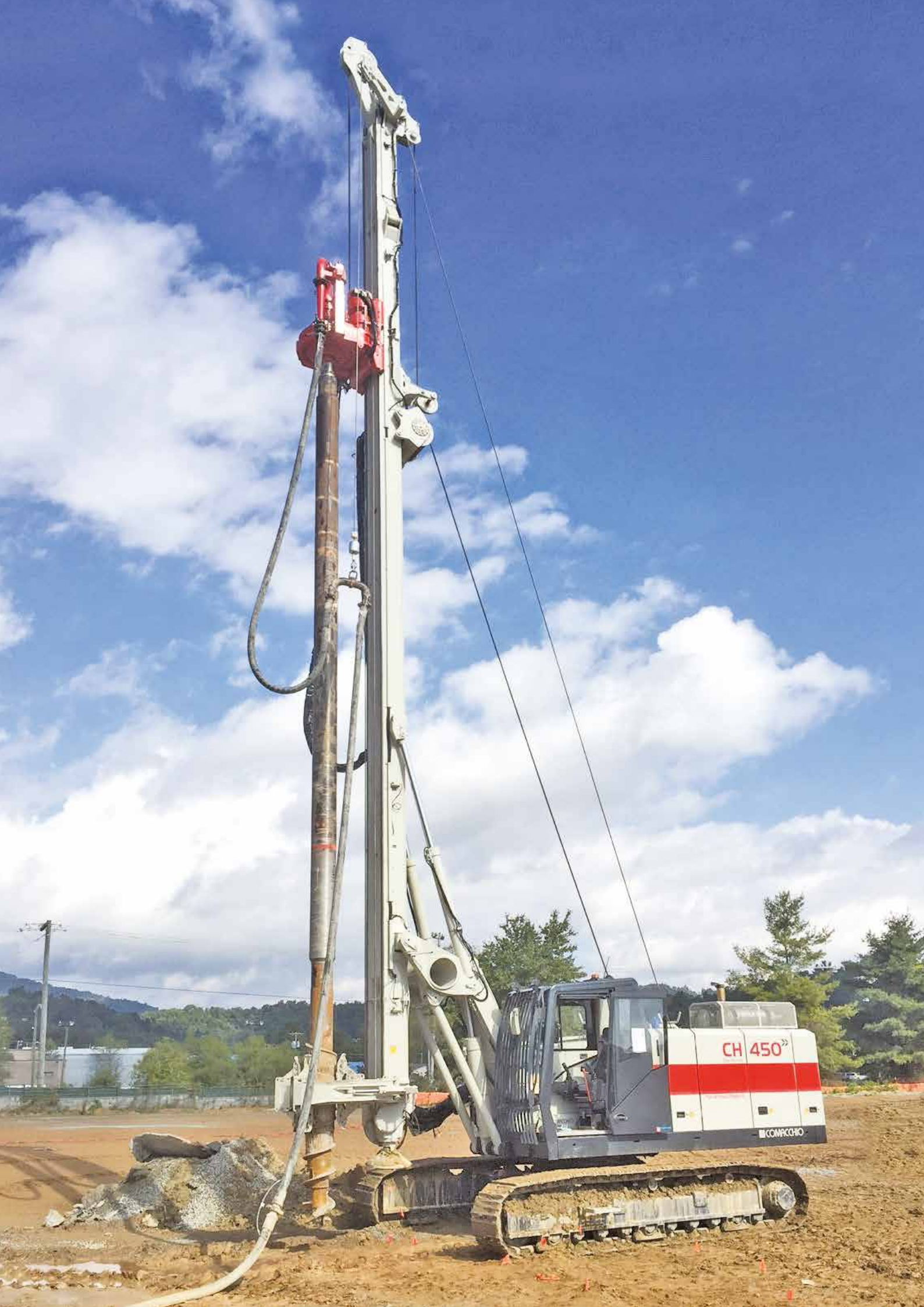

CH 450²

COMACCHIO

CH 450 - LDTH

Overall dimensions

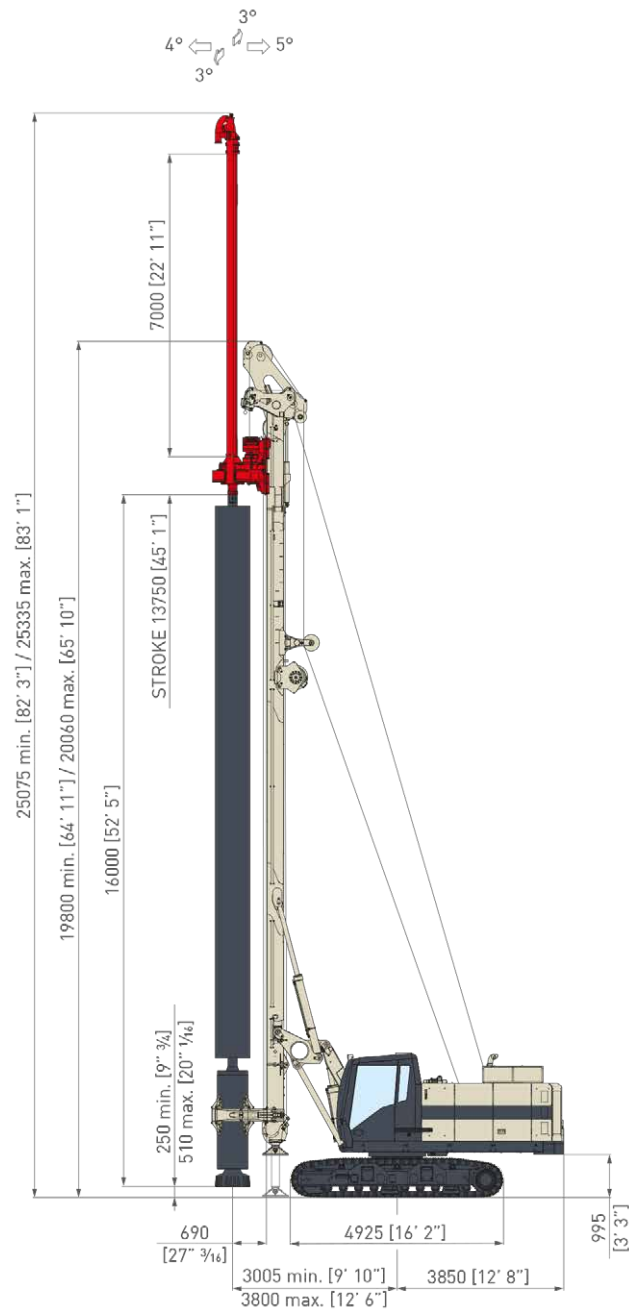

LDTH (Large DTH)

	m.s.	i.s.		
Max. pile diameter	mm	ft-in	1.000	3' 3"
Stroke c/w mast foot	m	ft-in	14,5	47' 7"
Max. pile depth	m	ft-in	Approx. 50 - 60 ⁽¹⁾	Approx. 164' - 196' ⁽¹⁾
Extraction force	kN	lbs	330	74,200
Operating weight w/o tool	kg	lbs	41.500	91,500

Note

(1) max. depth is upon drill string weight.



CH 450 - LHR

Overall dimensions

CPD standard

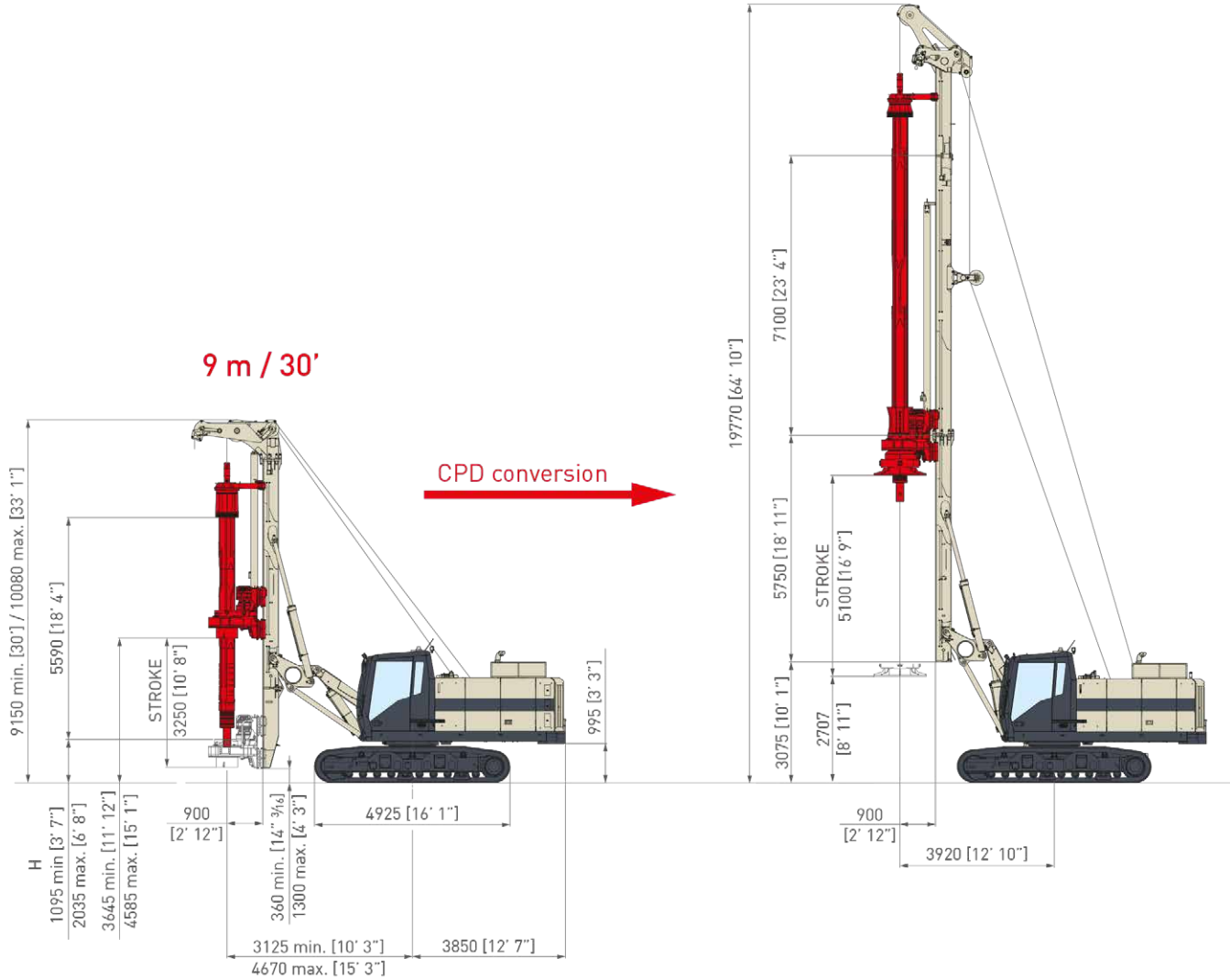

LHR (Low Head Room)	m.s.	i.s.	9 m / 30'		CPD standard	
Min. height	mm	ft-in	9.150	30'	19.766	64' 8"
Max. kelly bar length	m	ft-in	5,5	18'	12,5	41'
Stroke of pull down cylinder	mm	ft-in	3,250	10' 8"	5,100	16' 7"
Max. pile diameter	mm	ft-in		1.800	5' 11"	
Max. pile depth with 4-element kelly bar	m	ft-in	(4x5,5) 18,80	(4x18') 61' 8"	(4x12,5) 45,10	(4x41') 147' 11"
Max. pile depth with 5-element kelly bar	m	ft-in	(5x5,5) 23,15	(5x18') 75' 11"	-	-
Operating weight w/o tool	kg	lbs	40.100 ⁽¹⁾	88,400 ⁽¹⁾	43.400 ⁽²⁾	95,700 ⁽²⁾

Notes

(1) c/w 4 x 5,5 m [4 x 18' 1"] long 368 mm [14" 1/2] dia. Kelly bar.

(2) c/w 4 x 9 m [4 x 29' 6"] long 368 mm [14" 1/2] dia. Kelly bar; rotary c/w bucket opening flange.

CH 450 - LHR

Overall dimensions

14 m / 46'

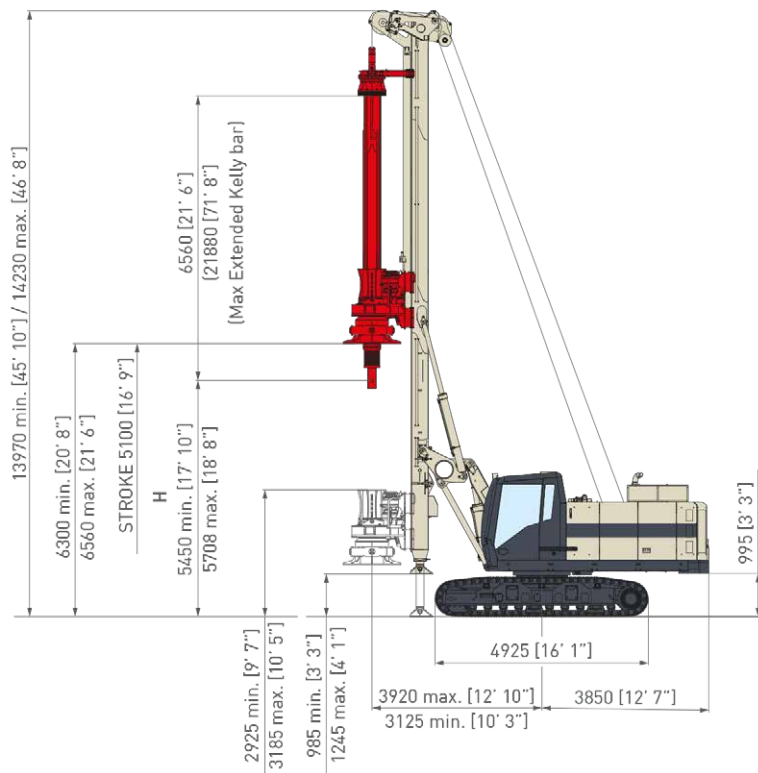

LHR (Low Head Room)	m.s.	i.s.	LHR 14 m / 46'	
Min. height	mm	ft-in	13.970	45' 10"
Max. kelly bar length	m	ft-in	8,0	26' 3"
Stroke of pull down cylinder	m	ft-in	5,10	16' 9"
Max. pile diameter	mm	ft-in	1.800	5' 11"
Max. pile depth with 4-element kelly bar	m	ft-in	(4x8) 28,80	(4x26' 3") 94' 6"
Max. pile depth with 5-element kelly bar	m	ft-in	(5x8) 35, 80	(5x26' 3") 117' 5"
Operating weight w/o tool	kg	lbs	42.400 ⁽¹⁾	93,500 ⁽¹⁾

Note

(1) c/w 4 x 6 m [4 x 19' 8"] long 368 mm [14" ½] dia. kelly bar; rotary c/w 1000 mm [40'] diam. cardan joint.

CH 450 - MP

Overall dimensions

DOUBLE HEAD

SINGLE HEAD

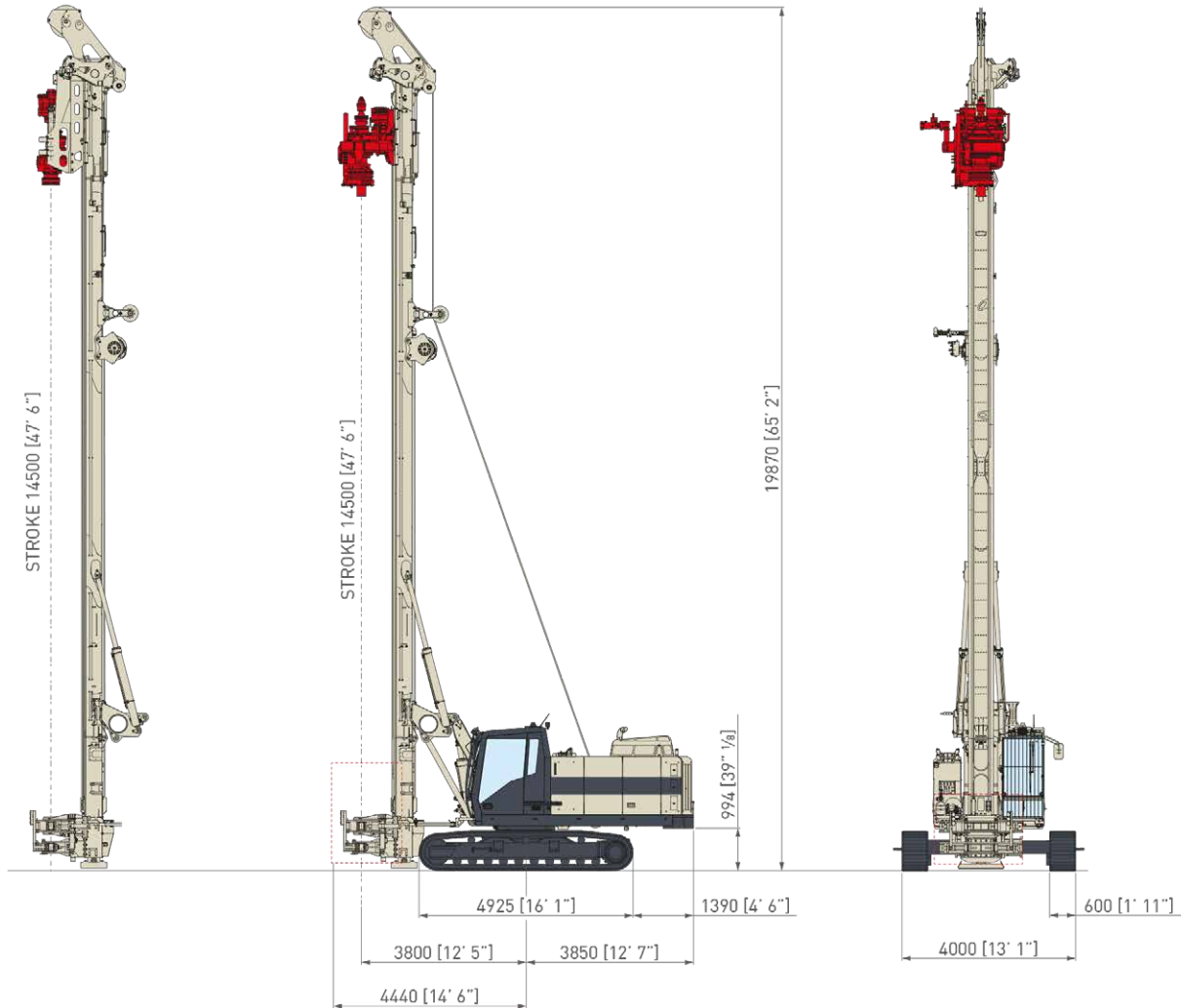

MP (Micropiles)	m.s.	i.s.	DOUBLE HEAD		SINGLE HEAD	
Max. feed force	kN	lbs	93	20,900	240	53,900
Max. retract force	kN	lbs	204	45,800	240	53,900
Mast						
Feed Stroke	mm	ft-in	14.500	47' 6"	14.500	47' 6"
Double clamp with casing extractor						
Clamping range	mm	in	120 - 620	4 3/4" - 24"	120 - 620	4 3/4" - 24"
Rotary head			Upper head		Lower head	
Model	-		R 2400S		R 10000	
Gears	-		3		4	
Max. torque	kNm	lbs-ft	24.7	18,200	106.2	78,300
Max. speed	rpm		97		36	
Operating weight w/o tool						
	kg	lbs	43.700	96,400	43.400	95,700

CH 450

Transport dimensions

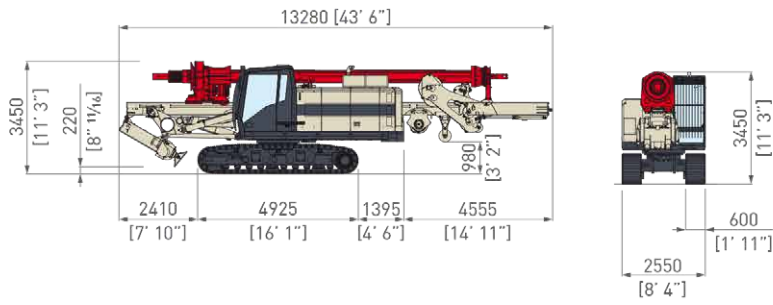

	m.s.	i.s.	WPD	
Transport weight	kg	lbs	44,800	98,800

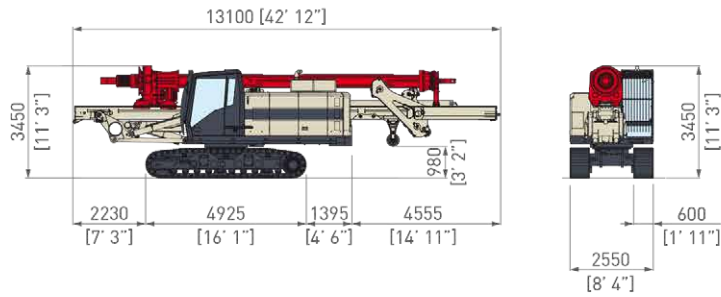

	m.s.	i.s.	CPD	
Transport weight	kg	lbs	43,100	95,000

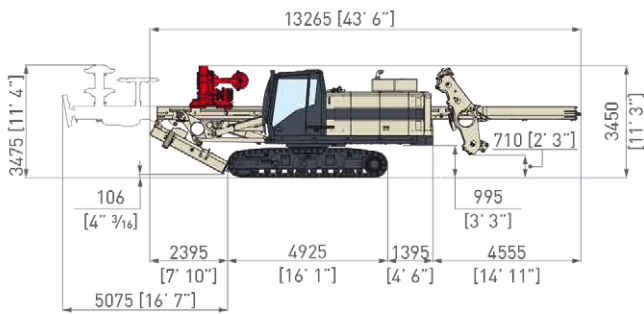

	m.s.	i.s.	CFA T4	
Transport weight	kg	lbs	40,500	89,300

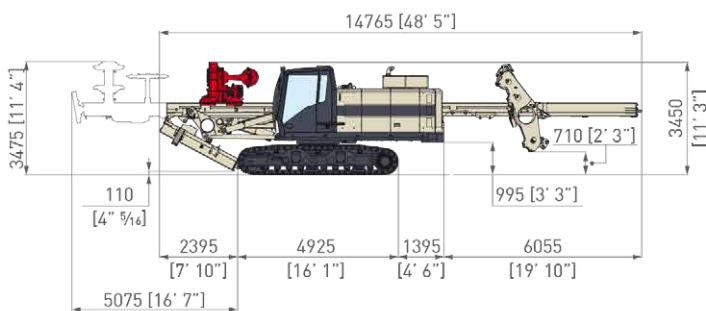

	m.s.	i.s.	CFA T4 XL	
Transport weight	kg	lbs	41,500	91,500

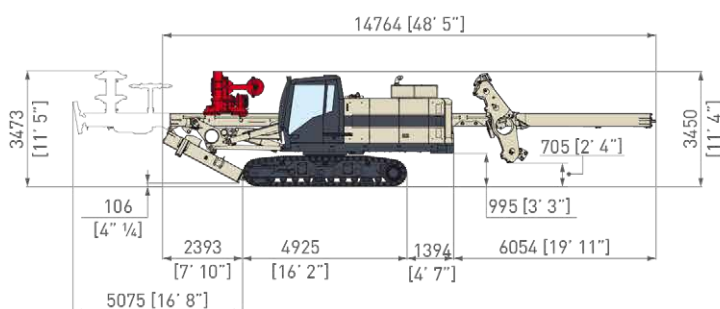

	m.s.	i.s.	CFA T4 XXL	
Transport weight	kg	lbs	43,700	96,300

CH 450 - LHR

Transport dimensions

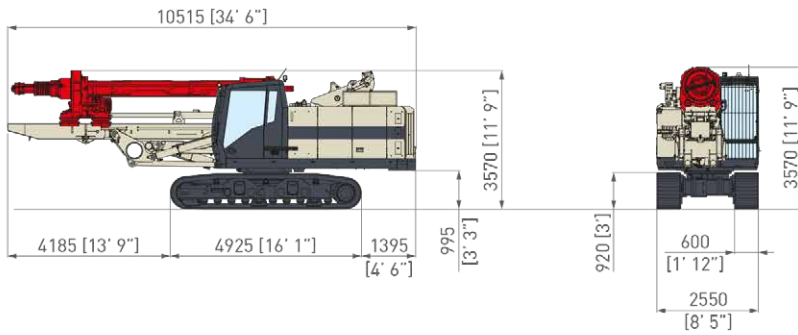

		m.s.	i.s.	LHR 9 m	
Transport weight		kg	lbs	40.100	88,400

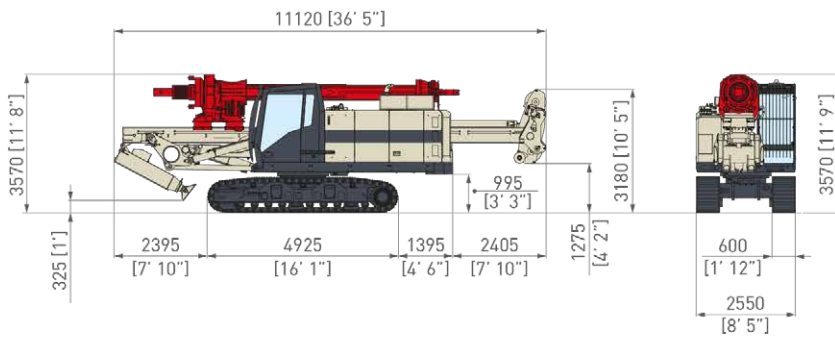

		m.s.	i.s.	LHR 14 m	
Transport weight		kg	lbs	42.000	92,600

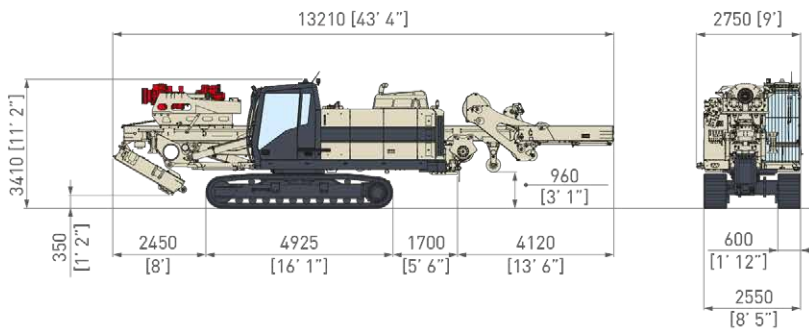

		m.s.	i.s.	MP (Double Head)	
Transport weight		kg	lbs	40.700	89,700

		m.s.	i.s.	MP (Single Head)	
Transport weight		kg	lbs	40.500	89,300



Comacchio S.p.A.

Via Callalta, 24/B - 31039 Riese Pio X (TV) (Italy)

Tel +39 0423 7585 - Fax + 39 0423 755592 - sales@comacchio.com