



FD 200

CFA Piling Rig





FD 200

CFA Piling Rig

Work configuration

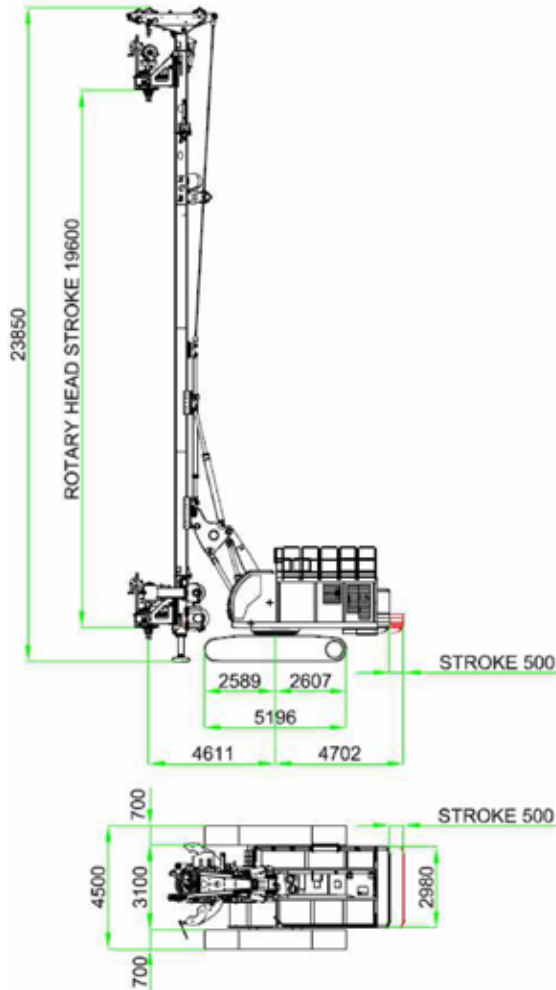

Transport configuration

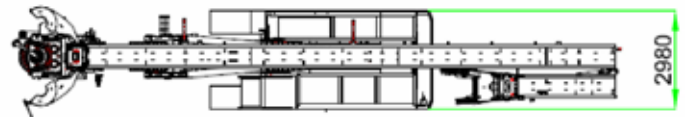
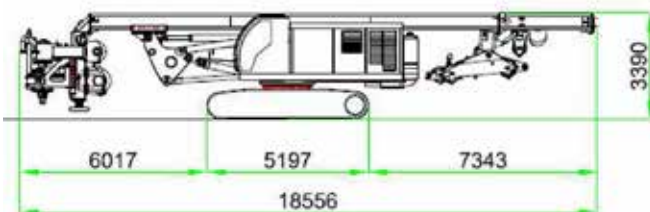

UNDERCARRIAGE

Width with closed tracks	2980	mm
Width with open tracks	4500	mm
Shoes width	700	mm
Length	5196	mm

DIESEL ENGINE

Type / Model	FPT - C87 ENT H W STAGE IV	
Power@ 2100 rpm	305	kW
Electrical system	24	V
Fuel Tank capacity	760	l

HYDRAULIC SYSTEM

Hydraulic pumps	1° circuit	360 - 320	l/min-bar
	2° circuit	360 - 320	l/min-bar
	3° circuit	108 - 320	l/min-bar
	4° circuit	48 - 140	l/min-bar
	5° circuit	234 - 60	l/min-bar
	6° circuit	68 - 140	l/min-bar
	7° circuit	21 - 40	l/min-bar
Hydraulic Oil Tank Capacity	750	l	

MAST (CFA configuration)

Total length	23250	mm	
Telescopic foot stroke	1600	mm	
Counter mast stroke	2500	mm	
Pull - down system	Winch		
Push / pull force	5500	daN	
Pull - down stroke	19600	mm	
Maximum depth recommended	<i>without extension</i>	19000	mm
	<i>with 2000mm extension</i>	21000	mm
	<i>with 5000mm extension</i>	24000	mm
Maximum diameter recommended	Ø 900	mm	
Mast inclinations	<i>lateral</i>	+ / -5	°
	<i>forward</i>	5	°
	<i>backward</i>	15	°

ROTARY HEAD T-20000

Maximum torque	20398	daN
Maximum speed	34.5	r.p.m.
Number of hydraulic motors	2	n°
Hydraulic motors displacement	6000	cm³

WINCHES

MAIN WINCH			
Pull force	1st layer	18000	daN
Speed		48	m/min
Rope diameter		Ø 26	mm
AUXILIARY WINCH			
Pull force	1st layer	10000	daN
Speed		45	m/min
Rope diameter		Ø 20	mm

WEIGHT

Total weight	59.5	ton
--------------	------	-----





N.C.B. srl
30020 TORRE DI MOSTO (VE) Italy
Via Confin, 65
tel. ++39 0421 325077-8
fax ++39 0421 325079
info@ncbinternational.net
www.ncbinternational.net