

# Hammer Equipment

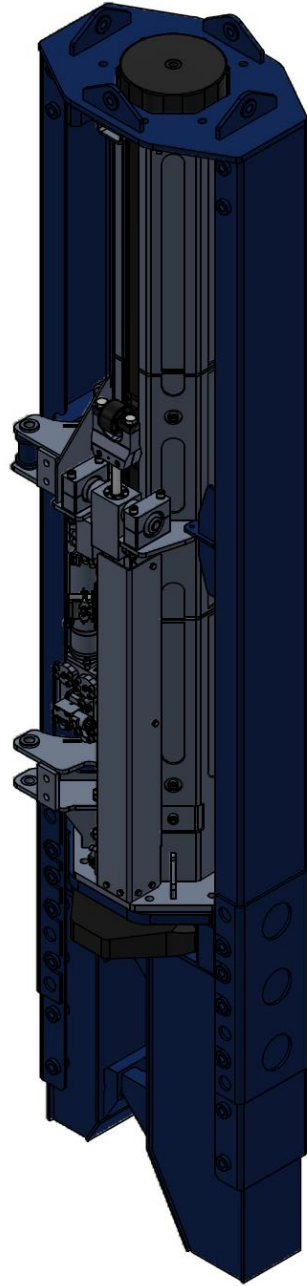

## Features:

- Low power consumption
- Hydraulic accelerated
- Modular construction allowing various options
- Clear and simple operation
- Short in length for longer piles

# IHE-30-SL

Specifications		IHE-30-SL
Max. Energy	kNm	30
Drop height	mm	50 - 1.000
Blow rate	Sl/min	40 - 110
Ram weight	kg	2000
Total weight	kg	3700
Max. Oil flow	l/min	90
Max. Work pressure	bar	240
P - R connection		1" - 1-1/4"
Dimensions		
A	mm	3150
B	mm	4500
C	mm	895
D	mm	660
Pile sizes		
Due to different inserts the hammer fits single and pairs of most U, Z and H sheet piles		
..		

## Options:

- Different leader guides
- Different pile caps and sleeves
- Silent package
- Leader guided on excavator
- Sheet pile leg grips
- Power-Pack
- Data system for monitoring the process

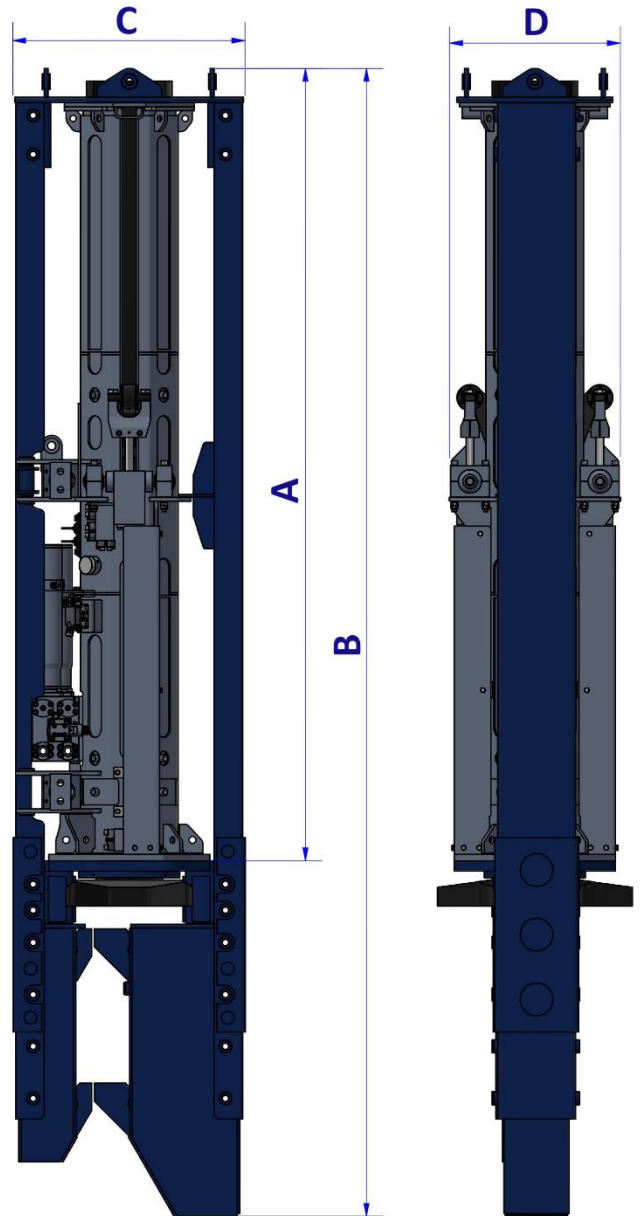

## INPIEQ,

Inpieq, your partner for foundation machines and associated equipment. In recent years INPIEQ has grown into a recognized provider of service, maintenance and further development of your machinery. With its own line of its own products.

Contact:

Liberatorstraat 3  
4651SC Steenbergen  
Nederland

T: +31 (0)164 687 740

I: [info@inpieq.nl](mailto:info@inpieq.nl)

W: [www.inpieq.nl](http://www.inpieq.nl)

We do not accept any responsibility for errors or omissions in this publication or other documents referred to by or linked to this publication. Please contact us for more information before relying on any information contained herein.