

INPIEQ Hammer Equipment

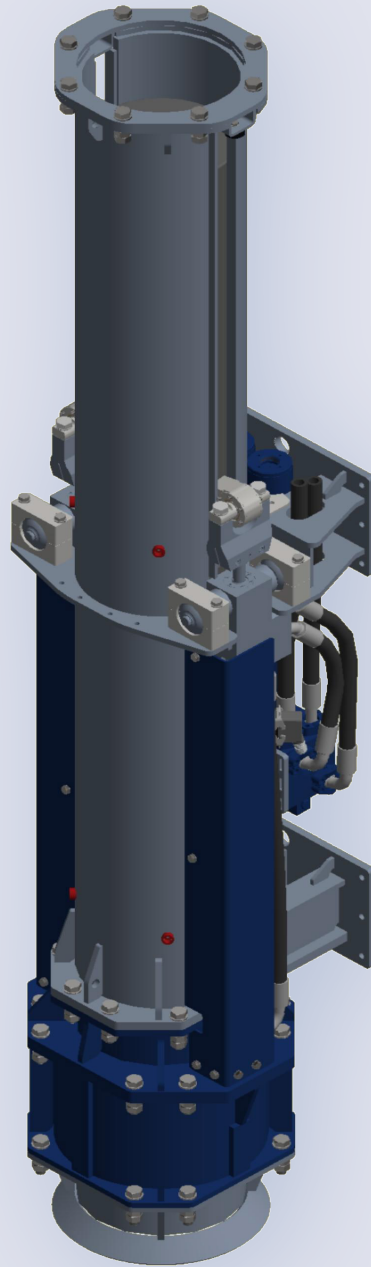

Features:

- Low power consumption
- Hydraulic accelerated
- Modular construction allowing various options
- Clear and simple operation
- Short in length for longer piles

INPIEQ Hammer Equipment

Specifications		IHE-20	IHE-30
Max. Energy	kNm	20	30
Drop height	mm	40 - 1.000	40 - 1.000
Blow rate	SL/ min	40 - 110	40 - 110
Ram weight	kg	1350	2000
Total weight	kg	2960	3700
Max. Oil flow	l/min	90	90
Max. Working pressure	bar	180	240
P - R connection		1" - 1-1/4"	1" - 1-1/4"

Dimensions			
A	mm	3460	3460
B	mm	3640	4305
C (Drive Cap: Type 1 / 2)	mm	700 / 740	740
D	mm	425	425
E (Drive Cap: Type 1 / 2)	mm	680	680

Pile sizes			
Max. tubular size	mm	457	457
Max. Concrete pile	mm	320	320

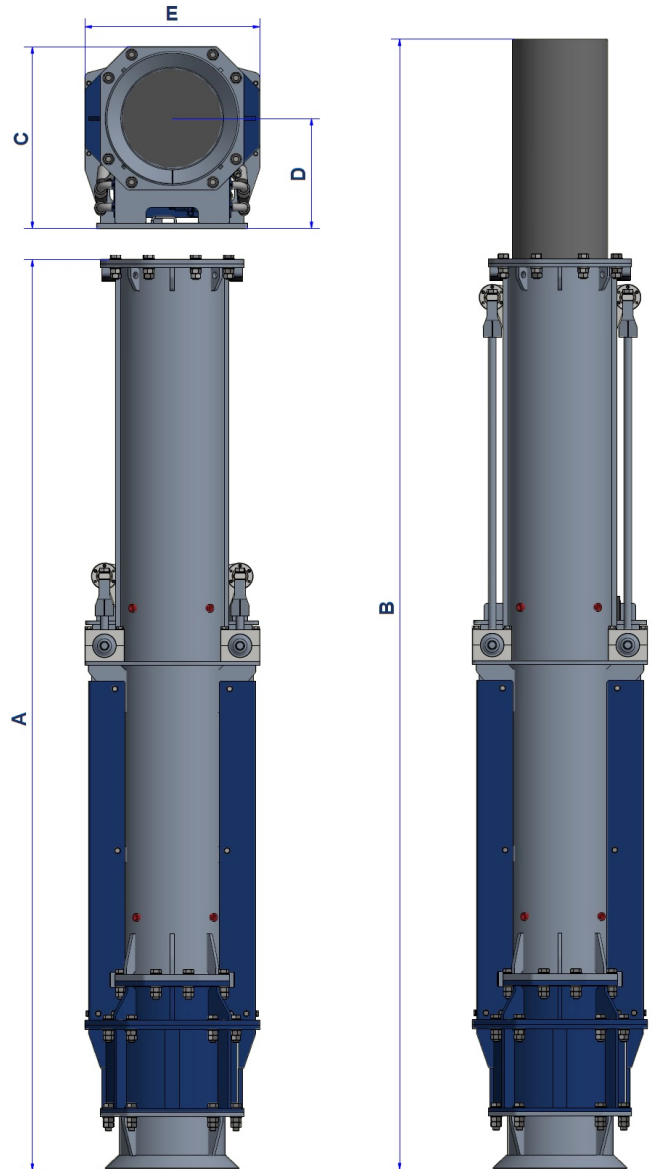

Options

- Different leader guides
- Different pile caps and sleeves
- Silent package
- Leader guided on excavator
- Sheet pile leg grips
- Power-Pack
- Data system for monitoring the process

We accept no responsibility whatsoever for errors or omissions in this publication or other documents referred to in this publication or linked to it. Due to improvements and technical progress, we reserve the right to make corrections without prior notice. Please contact us for more information before confiding or communicating any information contained in this document.