



**AGD Equipment Limited**

SALES • RENTAL • SERVICE • PARTS

**MINI CRANES**

**CRAWLER CRANES**

**TELESCOPIC CRANES**

**PILING RIGS  
AND EQUIPMENT**

**01789 292227**

**info@agd-equipment.co.uk**

AGD Equipment Limited  
Avonbrook House  
198 Masons Road  
Stratford-upon-Avon  
Warwickshire  
CV37 9LQ  
United Kingdom



**INPIEQ IHE-30-SL  
Impact Hammer  
with MÜLLER MS-A 190  
Power Pack**

[www.agd-equipment.co.uk](http://www.agd-equipment.co.uk)

# INPIEQ IHE-30-SL Vibratory Hammer

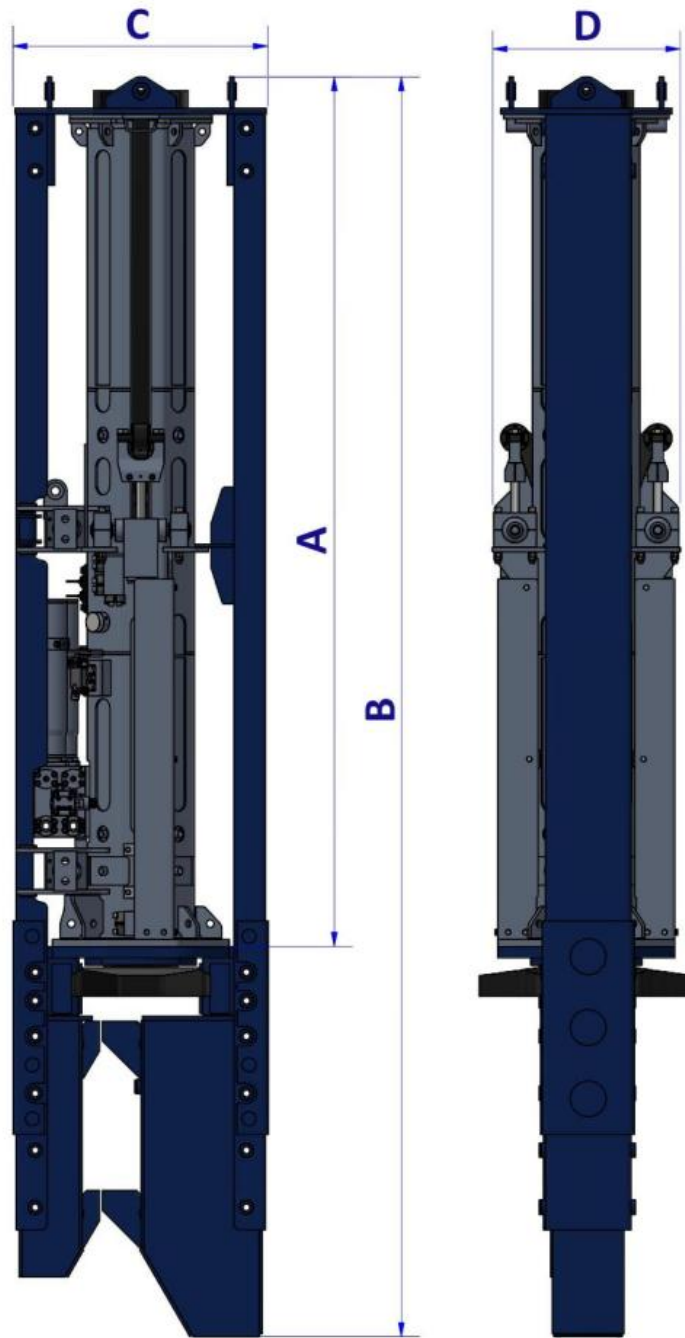

A	B	C	D
3150mm	4500mm	895mm	660mm

## Features

- Low power consumption
- Hydraulic accelerated
- Modular construction allowing various options
- Clear and simple operation
- Short in length for longer piles

## Options

- Different leader guides
- Different pile caps and sleeves
- Silent package
- Leader guided on excavator
- Sheet pile leg grips
- Power pack
- Data system for monitoring the process

## Technical Data

Max. Energy	kNm	30
Drop Height	mm	50 - 1000
Blow Rate	Sl/min	40 - 110
Ram Weight	kg	2000
Total Weight	kg	3700
Max. Oil Flow	l/min	90
Max. Work Pressure	Bar	240
P – R Connection		1" - 1¼"

\* without clamping device

Recommended power pack:      Type MS-A 190

# MÜLLER MS-A 190W Power Pack

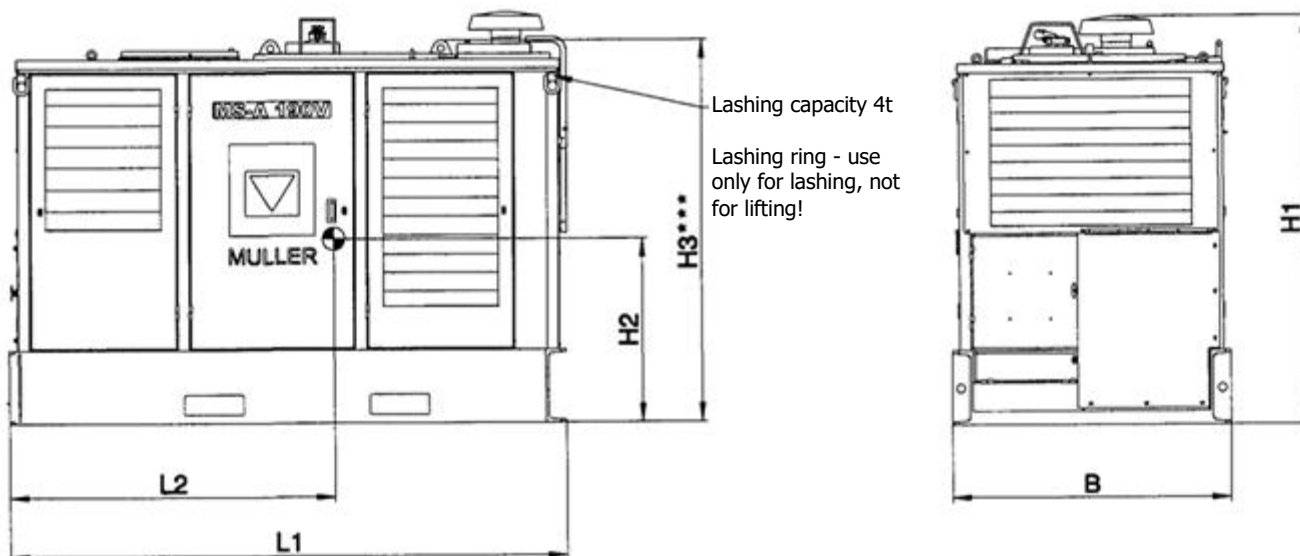

L1	L2	B	H1	H2	H3***
3000mm	1750mm	1500mm	2200mm	1000mm	2066mm

\*\*\* Shipping height (without rain cap, air suction and hoop guard, exhaust gas stub)

## Technical Data

Diesel Engine	CAT C7.1 ATAAC
Exhaust Certification EU/EPA	Stage 5
Performance	186 kW
Speed	2000 min <sup>-1</sup>
Fuel Tank Volume Max.	400 litres
Hydraulic Tank Volume Max.	500 litres
Weight without Fuel	Approx. 4700 kg

## Pump Equipment

Vibrator Drive Pumps	154 cm <sup>3</sup> /U
Delivery Max.	290 l/min
Working Pressure Max.	380 bar

Clamp Hydraulic Pump	10 cm <sup>3</sup> /U
Delivery	20 l/min
Working Pressure Max.	350 bar

## Cooler Equipment

Hydraulic Oil Cooler	
Oil-Air-Radiator	
Cooling Capacity	30 kW

Vibrator Gear Oil Cooler	
Oil-Air-Radiator	
Cooling Capacity	** kW

\*\* Optional – dependent on vibrator