



AGD Equipment Limited

SALES • RENTAL • SERVICE • PARTS

MINI CRANES

CRAWLER CRANES

TELESCOPIC CRANES

**PILING RIGS
AND EQUIPMENT**

01789 292227

info@agd-equipment.co.uk

AGD Equipment Limited
Avonbrook House
198 Masons Road
Stratford-upon-Avon
Warwickshire
CV37 9LQ
United Kingdom



NCB FD200 Specification

www.agd-equipment.co.uk



FD 200

CFA • FDP • Rigid Inclusions





FD 200

CFA • FDP • Rigid Inclusions

Work configuration

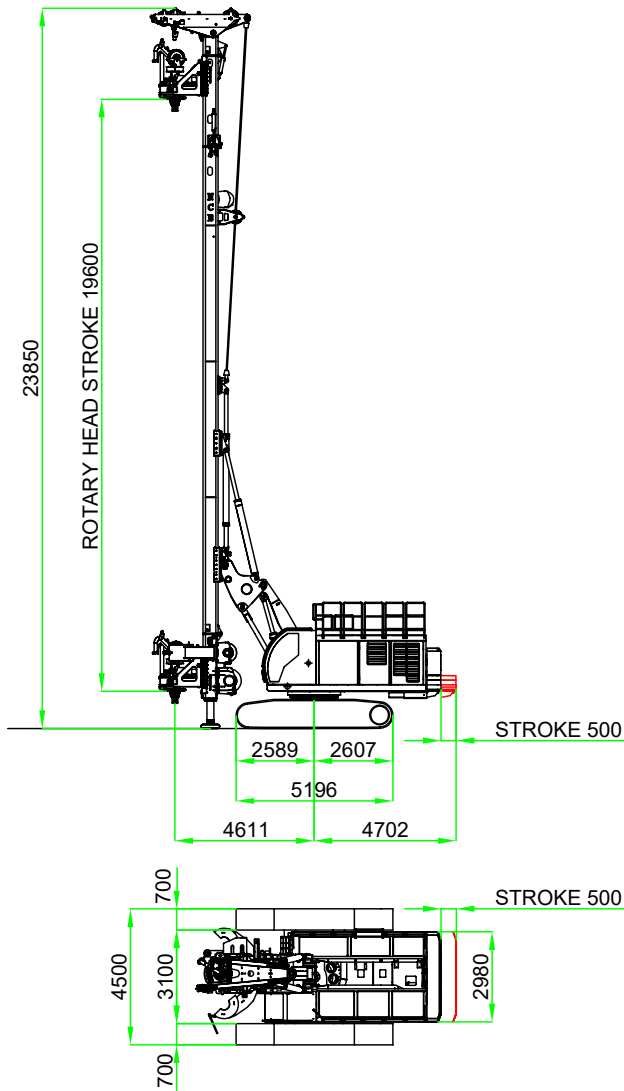

Transport configuration

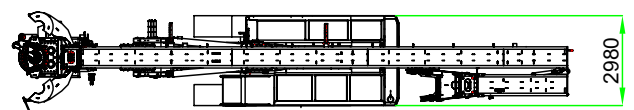
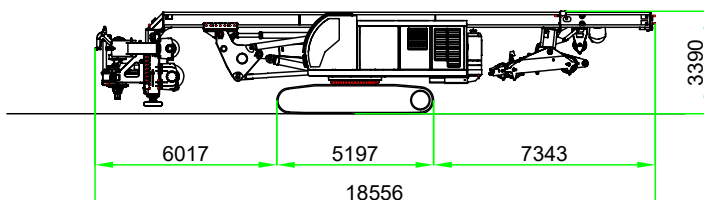

UNDERCARRIAGE

Width with closed tracks	mm	2980
Width with open tracks	mm	4500
Shoe width	mm	700
Length	mm	5196

DIESEL ENGINE

Type / Model	VOLVO	TAD 1383 VE	STAGE V
Power @ 1900 rpm		kw	315
Electrical system		V	24
Fuel Tank capacity		l	760

HYDRAULIC SYSTEM

Hydraulic pumps	1° circuit P1	l/min-bar (max)	360-320
	2° circuit P2	l/min-bar (max)	360-320
	3° circuit P3	l/min-bar (max)	108-320
	4° circuit P4	l/min-bar (max)	48-140
	5° circuit P5	l/min-bar (max)	234-60
	6° circuit P6	l/min-bar (max)	68-140
	7° circuit P7	l/min-bar (max)	21-40
Hydraulic oil tank capacity		l	750

MAST (CFA configuration)

Total length	mm	23250	
Telescopic foot stroke	mm	1600	
Counter mast stroke	mm	2500	
Pull - down system	Winch		
Pull - down rope	mm	Ø16	
Push / pull force	daN	5500	
Pull - down stroke	mm	19600	
Maximum depth recommended	<i>without extension</i>	mm	20000
	<i>with 2000mm extension</i>	mm	22000
	<i>with 4000mm extension</i>	mm	24000
Maximum diameter recommended	mm	Ø900	
Mast lateral inclinations	°	+/-5	
Mast forward inclinations	°	5	
Mast backwards inclination	°	15	

T-20000 ROTARY HEAD

Maximum torque	daNm	20398
Maximum speed	rpm	34.5
Number of hydraulic motors	n°	2
Hydraulic motors displacement	cm³	6000

WINCHES

MAIN WINCH		
Pull force (1st layer)	daN	18000
Speed	m/min	48
Rope diameter	mm	Ø26
AUXILIARY WINCH		
Pull force (1st layer)	daN	10000
Speed	m/min	45
Rope diameter	mm	Ø20

WEIGHT

Approx weight	<i>without auger</i>	ton	60
---------------	----------------------	-----	----

NOTES

- Remote control for loading and unloading operations and for rig set up of the working configuration;
- NCB software ;
- Overturning of the cathead and the upper extension by hydraulic cylinders;
- Counter mast;
- Extendable undercarriage;
- Extendable counterweight;



FD 200



N.C.B. srl

📍 30020 TORRE DI MOSTO (VE) Italy
Via Confin, 65

☎ tel. +39 0421 325077-8
fax +39 0421 325079

✉ info@ncbinternational.net
🌐 www.ncbinternational.net

📘 **NCB International**

🌐 **NCB International**